

# PELVIPERINEOLOGY

## CONTENTS

### 62 In the Path of Giants - KEES WAALDIJK

JACOB BORNSTEIN and DARREN M.GOLD

#### Review

### 65 Urinary incontinence during sexual intercourse

BOGDAN GEORGE ILEANA, RENATA CIOBANU, TRAIAN ENACHE

#### Original Articles

### 68 Pelvic floor muscle group therapy for the treatment of urinary incontinence during pregnancy and post-partum: a randomized controlled trial

HEIDI F.A. MOOSSDORFF-STEINHAUSER, BARY C.M. BERGHMANS, MARC E.A. SPAANDERMAN, ESTHER M.J. BOLS

### 77 Clinical and subjective outcomes of abdominal mesh surgery (sacrocolpopexy and sacrohysteropexy) for apical prolapse: a single-center experience

MONIKA ANANT, AMRITA SINGH, SHWETA GUPTA, MUKTA AGARWAL, SANGAM KUMARI, ANITA PASWAN

### 84 Kees classification of obstetric and other urine fistulas as based on quantitative and qualitative pelvis tissue loss and on the continence mechanism

KEES WAALDIJK

### 90 Long-term effects of a placebo-controlled trial of enoxaparin for treatment of severe provoked vulvodynia

ELAD OFIR, EILAM PALZUR, JACOB BORNSTEIN

### 97 Diagnosis and pathophysiology of Hirschsprung's disease

MICHAEL D. LEVIN

### 104 Removal time of postoperative vesical catheter in utero-vaginal prolapse surgery: a comparative study

EDGARDO CASTILLO-PINO, NATALIA BENAVIDES, VALENTINA ACEVEDO, VALERIA ALONSO

#### Case Report

### 110 Chronic pelvic pain associated with Nutcracker Phenomenon and pelvic congestion: a case report

ILEANA SÄNGER, OSCAR ROMERO GURAL, CARLOS SARSOTTI, MARTINA SANTILLÁN ITURRES

2021

Volume: 40

Issue: 2

June



Societatea Română de Uroginecologie





- »» PROFESSIONAL APPROACH TO ACADEMIC PUBLISHING
- »» SCIENTIFIC JOURNAL INDEXING SYSTEMS
- »» PROVIDING CONSULTING SERVICES TO MANY INDEXES
- »» INDEX DATABASES WE COLLABORATE  
WAME, ICMJE, CSE, EASE, COPE
- »» CONDUCTING STUDY ANALYSES



REDUCTION AND  
TRANSLATION



DESIGN WORKS



E-PUBLICATION



TYPESETTING AND  
PRINTING SERVICES

## EDITORIAL BOARD

### Editor in Chief

JACOB BORNSTEIN, Obstetrics and Gynaecology, Israel

### Senior Editors

ANDRI NIEUWOUTD, Gynaecology, Netherlands -

PETER PETROS, Gynaecology, Australia - AKIN SIVASLIOGLU, Urogynaecology, Turkey - ERAY CALISKAN Urogynaecology, Turkey  
- ELVIRA BARBULEA BRATILA, Romania

### Editor Emeritus

GIUSEPPE DODI, Colorectal Surgery, Italy - BRUCE FARNSWORTH, Gynaecology, Australia

### Editorial Board

BURGHARD ABENDSTEIN, Gynaecology, Austria

DIANA BADIU, Gynaecology, Romania

ANTONELLA BIROLI, Physiatry, Italy

CORNEL PETRE BRATILA, Gynaecology, Romania

SHUKING DING, Colorectal Surgery, P.R. China

TRAIAN ENACHE, Urogynaecology, Romania

ENRICO FINAZZI - AGRÒ, Urology, Italy

KLAUS GOESCHEN, Urogynaecology, Germany

DARREN M. GOLD, Colorectal Surgery, Australia

WOLFRAM JAEGER, Gynaecology, Germany

DIRK G. KIEBACK, Gynaecology, Germany

FILIPPO LA TORRE, Colorectal Surgery, Italy

MICHAEL D. LEVIN, Pediatric radiology, Israel

BERNHARD LIEDL, Urology, Germany

NAAMA MARCUS BRAUN, Urogynaecology, Israel

ANDRI MULLER FUNOGEA, Gynaecology, Germany

MENAHEN NEUMAN, Urogynaecology, Israel

PAULO PALMA, Urology, Brazil

MARC POSSOVER, Gynaecology, Switzerland

RICHARD REID, Gynaecology, Australia

GIULIO SANTORO, Colorectal Surgery, Italy

YUKI SEKIGUCHI, Urology, Japan

MAURIZIO SERATI, Urogynaecology, Italy

DMITRY SHKAPURA Urogynaecology, Russia

SALVATORE SIRACUSANO, Urology, Italy

MARCO SOLIGO, Gynaecology, Italy

JEAN PIERRE SPINOSA, Gynaecology, Switzerland

MICHAEL SWASH, Neurology, UK

VINCENT TSE, Urology, Australia

PETER VON THEOBALD, Gynaecology, Reunion Island, France

FLORIAN WAGENLEHNER, Urology, Germany

ADI Y. WEINTRAUB, Urogynecology, Israel

PAWEL WIECZOREK, Radiology, Poland

QINGKAI WU, Urogynaecology, P.R. China

ANASTASIYA ZAYTSEVA Urogynaecology, Russia

CARL ZIMMERMAN, Gynaecology, USA

### Section Heads

Aesthetic gynecology - RED ALINSOD (USA)

Andrology - ANDREA GAROLLA (Italy)

Challenging cases - VITO LEANZA (Italy)

Chronic pelvic pain - MAREK JANTOS (Australia)

Imaging - VITTORIO PILONI (Italy)

Intestinal rehabilitation and neurogastroenterology -

GABRIELE BAZZOCCHI (Italy)

Pelvic floor rehabilitation - DONATELLA GIRAUDO (Italy),

GIANFRANCO LAMBERTI (Italy)

Psychology - ANDREA AMBROSETTI (Italy)

Sacral neurostimulation - MARIA ANGELA CERRUTO (Italy)

Sexology - OSCAR HORKY (Australia)

Systematic reviews - STERGIOS K. DOUMOCHTISIS (UK)

Statistics - CARLO SCHIEVANO (Italy)

Editorial Office: International Society for Pelviperineology

e-mail: [editorinchief@pelviperineology.org](mailto:editorinchief@pelviperineology.org)

Quarterly journal of scientific information registered at the Tribunale di Padova, Italy n. 741 dated 23-10-1982 and 26-05-2004

The journal is property of the International Society for Pelviperineology



#### Publisher Contact

Address: Molla Gürani Mah. Kaçamak Sk.

No: 21/1 34093 İstanbul, Turkey

Phone: +90 (212) 621 99 25

Fax: +90 (212) 621 99 27

E-mail: [info@galenos.com.tr](mailto:info@galenos.com.tr)

[yayin@galenos.com.tr](mailto:yayin@galenos.com.tr)

Web: [www.galenos.com.tr](http://www.galenos.com.tr)

Publisher Certificate Number: 14521

Printer: La Grafica Faggian, Via F. Severi 2/4

Campodarsego (Padova) IT

E-mail: [comm@lagraficafaggian.it](mailto:comm@lagraficafaggian.it)

Printing Date: June 2021

ISSN: 1973-4905 E-ISSN: 1973-4913

International scientific journal published quarterly.

**Official Journal of the:** International Society for Pelviperineology  
([www.pelviperineology.com](http://www.pelviperineology.com))

Asociación Latinoamericana de Piso Pelvico

Perhimpunan Disfungsi Dasar Panggul Wanita Indonesia

The Israeli Society of Urogynecology and Pelvic Floor

Romanian Uro-Gyn Society

Pelvic Reconstructive Surgery and Incontinence Association (Turkey)

# pelviprost<sup>®</sup>

## PEA-um

Ultramicronized Palmitoylethanolamide 400 mg

## PEAPOL-m

(Palmitoylethanolamide co-micronized with Polydatin) 440 mg

Efficacious control of morphofunctional symptoms and signs in case of chronic inflammatory prostatitis (**cp/cpps**) and benign prostatic hyperplasia.

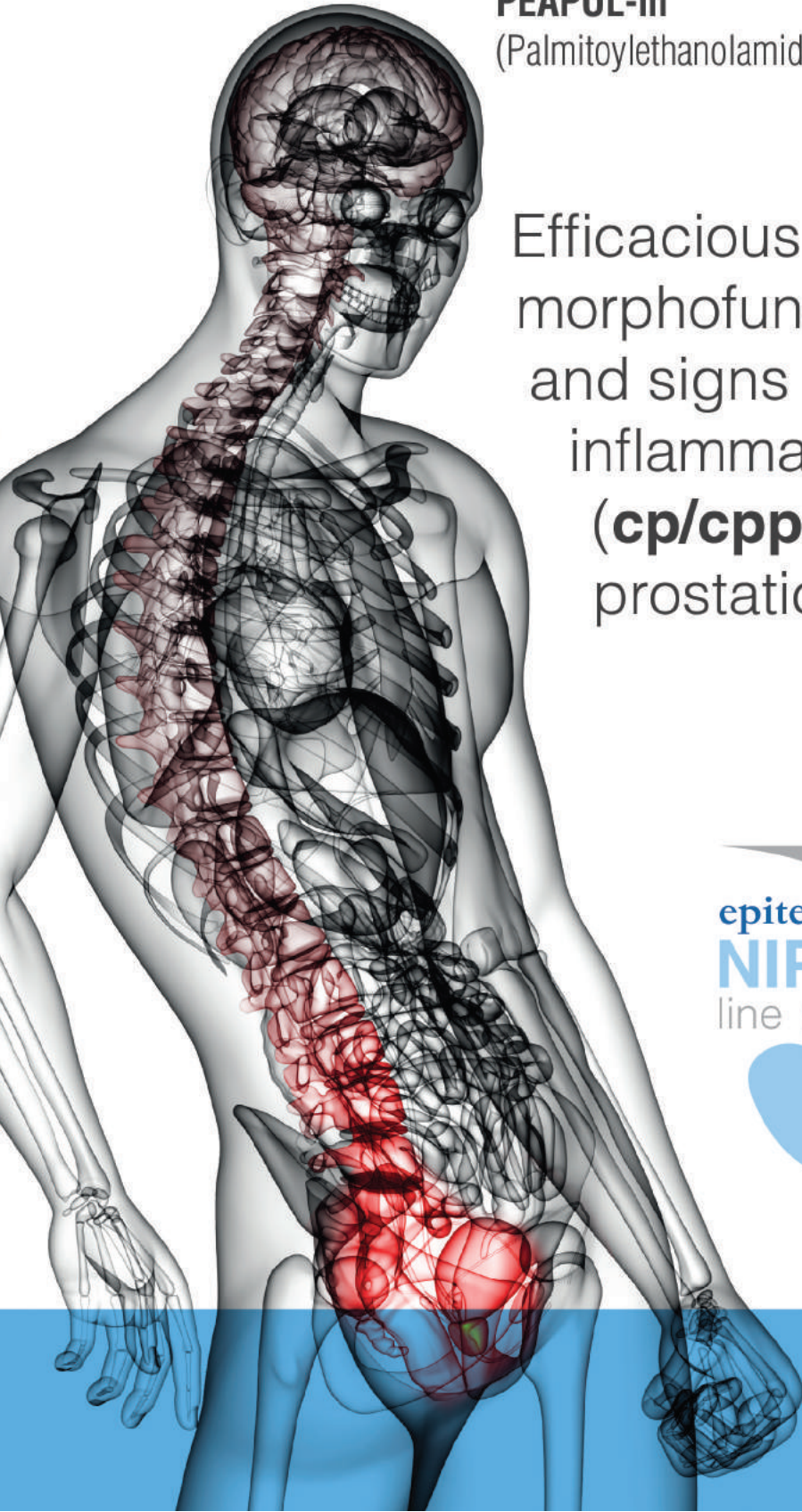

Packaging 20 tablets

**epitech**  
group  
[www.epitech.it](http://www.epitech.it)

## IN THE PATH OF GIANTS

Pelviperineology 2021;40(2):61-63

This section in Pelviperineology Journal, aims to interview the outstanding clinicians and scientists that had a special impact on the profession of Pelviperineology over the years.

### Dr. Kees Waaldijk

**Interviewers: Jacob Bornstein, Darren M. Gold, Pelviperineology**

Dr. Kees Waaldijk is MD, PhD. He is one of the heroes in the fight against obstetric fistula. He is considered to be one of the most experienced fistula surgeons in the world. He has performed tens of thousands of repair surgeries throughout his career.

Dr. Waaldijk is also a master trainer in the International Federation of Gynecology and Obstetrics (FIGO) surgeon training program, and has trained hundreds of doctors, nurses, and midwives in obstetric fistula treatment. Dr. Waaldijk is committed to evidence-based practices and documentation of results. In the present issue of Pelviperineology he publishes his terminology of obstetric fistulas.

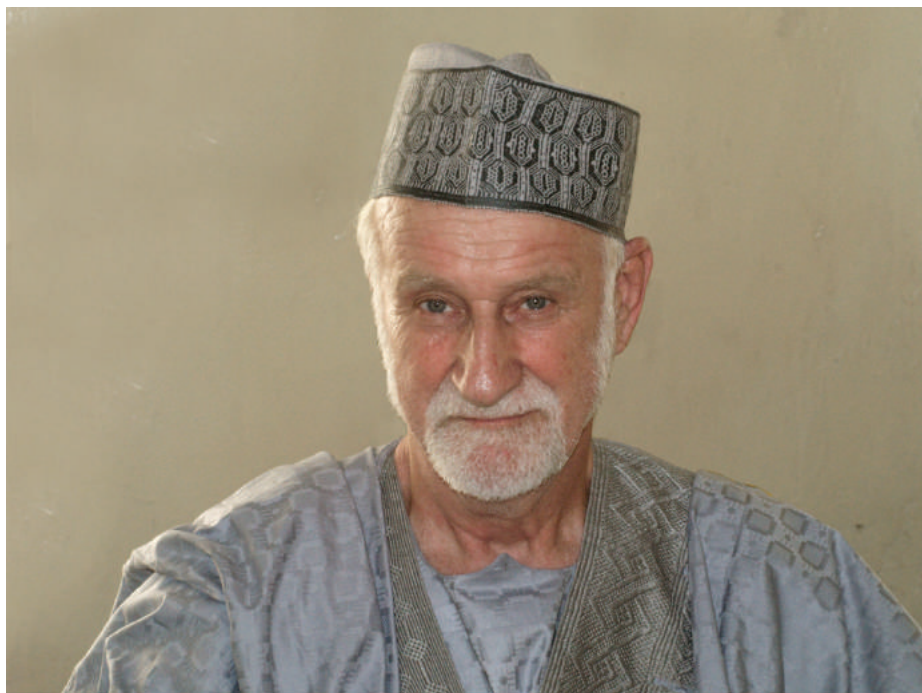

Dr. Kees Waaldijk wearing the traditional Hausa dress. After working for 25 years in Hausa land, one of his friends told him that he had to dress like the natives

#### • Dr. Kees Waaldijk, what is your background?

I was born in Amsterdam where I grew up, was schooled, and studied medicine. Having finished my medical education, I joined the army on a compulsory basis. Having served my time, I prepared myself to work in Africa with a postgraduate course in tropical medicine and further training in surgery and obstetrics and gynecology as required. Then, after further

training in leprosy in Ethiopia, I moved to Kenya where I worked in a coastal district hospital as the only medical officer of health, with nine highly trained medical assistants for a population of some 250,000 persons, for 2.5 years, for all health aspects, with a special assignment on leprosy and tuberculosis. During these 2.5 years, I performed quite a number of surgical, but especially obstetric and gynecologic procedures. Returning to Holland for the secondary schooling of my children, I started a residency

training in obstetrics/gynecology which I resigned as I did not want to concentrate on that specialty alone for the rest of my life. I then moved to Germany to complete my training in surgery and traumatology and worked as senior physician in surgery for some eight years, where I obtained ample experience in all kinds of surgery and traumatology, including colorectal, thyroid, breast and some vascular procedures, including implantation of dual chamber cardiac pacemakers, all types of osteosynthesis and intensive care with parenteral nutrition. During this period, I spent six months as a military surgeon in the largest Cambodian refugee camp in Thailand where I witnessed the direct and long-term effects of conventional warfare. Eventually, I went to northern Nigeria for a leprosy control and care project where I met my destiny.

#### • How did you end up taking care of obstetric fistulas?

Actually, we found each other. Since there was no specialist obstetrician and gynecologist available in the whole of Katsina province, I went three times a day - morning, afternoon, and late night, to help in the maternity unit in Katsina town, in addition to working with leprosy patients. The worst cases I saw there were ten maternal deaths, 40 stillborn children and 15 internal version and podalic extractions because of a delayed labor with an arm prolapse for one week. I was approached by the staff to see if I could care for obstetric fistula patients. Although I had never performed a fistula repair, I had lots of surgical experience. I successfully operated on one fistula and then it continued. In the small leprosy hospital, I did my repairs in the morning and my leprosy field work in the afternoon, visiting 175 leprosy clinics where we asked if there were any obstetric fistulas as these should come to the hospital. The first 500 patients operated on, were treated in the same female ward and beds as the female leprosy patients, until we were able to construct a postoperative ward.

#### • What motivated you to continue your work with fistula patients?

From the time I was 12 years old there was only one thing in my mind: I wanted to become a surgeon and to help people in a developing country. Life is suffering, but some do suffer more than others. My drive was, is and will always be, to lessen the suffering within my possibilities in a professional way, out of compassion since we all have to die, but all of us do not have to suffer.

#### • What is your main achievement?

The immediate management of a fistula by inserting a urinary catheter and/or early closure instead of the previous approach



A 15-year-old girl supporting herself with home made crutches. She presented with a fistula and could not stand or walk due to the enormous obstetric trauma resulting from a prolonged obstructed labour. Dr. Kees Waaldijk had to wait for two months before she could be operated upon. Following surgery, she recovered completely, became dry and could walk normally. (The patient gave consent for publication of her photograph)

of laissez-faire, of doing nothing for 3 months; The active immediate management is highly effective and will prevent the woman from becoming an outcast.

#### • What prepared you to become top notch in your field?

Honestly, nothing, I never thought I would write a scientific article not to mention getting a PhD degree; it just evolved over time along with an accumulation of enormous experience with



The damage to that metal bed is due the uncontrollable leaking of urine by the patients who have been sleeping on it; this depicts the aggressiveness of the urine

the management of obstetric trauma, including the obstetric fistulas in all its forms.

**• How did you proceed to determine what was the scientific truth?**

I am still in a learning process, since the scientific truth of yesterday is not the scientific truth of today, which will not be the scientific truth of tomorrow.

**• What did you first notice that alerted you that our current understanding of the subject was incorrect?**

At an early state I noticed that the fistula was part of a far greater extensive obstetric trauma and that it could only be solved by a holistic reconstruction of the functional pelvic anatomy instead of concentrating on only closing the fistula.

**• How did you know that you were right with your new approach?**

I am a documentation freak; even though for years I did not have electricity, I hammered out on an old typewriter all the

data including operation reports and follow up by an oil lamp and then later on, evaluating if what I was doing was OK or not; the high numbers were a curse since there was no time to think, but also a blessing, as they gave me a quick answer.

**• Looking backwards would you have done anything differently?**

I feel privileged that I am allowed to do all these positive reconstructive works, that I found in life what I was looking for - though I never knew what I was looking for... and that my work became my hobby. I achieved far more than I ever thought. However, I discovered everything myself the hard way; yes, the life of an obstetric fistula surgeon is not easy.

**• Can you quote the main publications that reflect your achievements?**

All my annual evaluation reports and my series “obstetric trauma surgery; art and science”. It includes so far 30 books, where I try to explain the obstetric trauma in relation to the functional pelvis anatomy, the characteristics of the enormous variety of trauma, the mechanism of action, and a step-by-step approach how to deal with these defects, in a systematic way. I directed it for a greater public in order to contribute, to lessen the suffering of the unfortunate women.

**• Any advice to new physicians in the field?**

Do your best to get your own insight and your own experience. Be honest to yourself about your own performance. This is how I performed in the most complicated challenge I ever encountered with obstetric trauma/fistula reconstructive surgery.



# Urinary incontinence during sexual intercourse

BOGDAN GEORGE ILEANA, RENATA CIOBANU, TRAIAN ENACHE

Prof Dr Panait Sarbu Obstetrics and Gynaecology Hospital, Bucharest, Romania

## ABSTRACT

In the present review, based on the literature data search, we suggest the urinary incontinence during sexual intercourse is an under-reported disorder among women with urinary incontinence. Urinary incontinence during sexual intercourse is defined as “complaint of involuntary loss of urine during coitus” according to the International Urogynecological Association and the International Continence Society in 2010.

This review was conducted by screening and gathering results of research papers from PubMed and Medscape. External sources were not used. Relevant studies were searched by using keywords: urinary leakage during sexual intercourse, coital incontinence, urinary incontinence during sexual intercourse, female urinary incontinence during intercourse.

In PubMed we found 14 articles of which 8 included only an abstract. In Medscape we have found 1 article. In the end only six articles were appropriate for analysis.

Finally, based on literature screening we find that, the prevalence of coital incontinence in women with urinary incontinence was high. We sustain the fact that urinary incontinence during sexual intercourse is a disease that can affect sexual life and is under-reported.

**Keywords:** Urinary incontinence; urinary continence; coital urinary incontinence; female urinary incontinence during intercourse

## INTRODUCTION

Urinary incontinence during sexual intercourse is an under reported disorder among women with urinary incontinence. That is a common, but under-reported symptom that adversely affects sexually-active women.<sup>1,2</sup>

Coital incontinence deserves particular focus as it is often directly associated with sexual dysfunction. Women can have urine leakage either during sexual activity, or when having an orgasm, or with both. Sexual stimulation can put pressure on the bladder or on the urethra. When combined with weakened pelvic floor muscles, this pressure can lead of stress incontinence. Urine leakage during orgasm, is often because of bladder spasm.<sup>1-3</sup>

Coital incontinence during penetration may be due to the alteration of the urethrovesical angle and elevation of the bladder neck by the erect penis during moments of increased intra-abdominal pressure. The mechanism of urinary incontinence during orgasm is unclear. It is postulated that penile stimulation of the nerve rich area of the bladder base and trigone may trigger detrusor overactivity in those with severe overactive bladder. Alternately, stimulation of the vanilloid receptors in this area, which are reportedly increased in density in patients with urgency, may trigger detrusor contractions.<sup>3-5</sup>

Female ejaculation may also cause some women to experience an expelling of fluid at orgasm. Some researchers claim that it's only urine that is expelled, but others consider that the paraurethral glands create a fluid that is excreted during orgasm.<sup>2,4,6</sup>

**Address for Correspondence:** Traian Enache, Prof Dr Panait Sarbu” Obstetrics and Gynaecology Hospital, Bucharest, Romania

**E-mail:** dr.traianenache@gmail.com ORCID ID: orcid.org/0000-0002-3585-2946

**Received:** 14 February 2021 **Accepted:** 14 April 2021

©Copyright 2021 by the International Society for Pelviperineology / Pelviperineology published by Galenos Publishing House.



The paraurethral glands, also known as the Skene's glands, come together in a cluster at the outside opening of a woman's urethra. They produce a clear or whitish fluid. This fluid may also serve to moisten both the urethra and the tissue surrounding the vagina.<sup>1,2,6</sup>

The tissue surrounding the paraurethral glands is adhered to the vagina and clitoris, and these glands can be stimulated through the vagina. Some people believe this is the controversial G-spot, or the erotic zone that is said to yield greater arousal and stronger orgasms.<sup>1,2,6</sup>

Risk factors for coital incontinence include severity of incontinence, obesity, parity, and anterior and posterior vaginal wall prolapse. The severity of the coital incontinence may be associated with the degree of sexual dysfunction.<sup>1,4,6</sup>

Several high level, large trials support the idea that pelvic floor muscle training can significantly decrease urinary-related sexual problems as well as improve sexual physiological response in the areas of desire, arousal, lubrication, orgasm, and satisfaction. These improvements may be correlated to increased pelvic muscle strength. Coital urinary incontinence was found to be improved with muscle training. Pelvic muscle training, in combination with biofeedback and occasionally transvaginal electrical stimulation, is also used to treat urgency urinary incontinence. The effect on sexual function in this population has not been extensively studied, and involves mostly small case series.<sup>2,6</sup>

## Materials and methods

### Literature search

This systematic review was conducted by screening and gathering results of research papers from literature search in PubMed database and Medscape database. External sources were not used. Relevant studies were searched by using keywords: urinary incontinence during sexual intercourse, coital incontinence, coital urinary incontinence.

### Data extraction

We gathered all of full text articles that met inclusion criteria. The results from six research articles that are relevant to this review were analysed.

## Results

### Study characteristics

We found six articles from PubMed and Medscape, we select articles only in English language and excluded articles with the texts in French and Spanish.

In the study of Grzybowska ME and Wydra DG<sup>3</sup> coital incontinence was reported in 65.35% on women. The frequency of coital incontinence was correlated with lower educational level and higher body mass index. In that article the authors concluded that women with coital incontinence were significantly more likely to admit that fear of incontinence or fear of embarrassment restricted their sexual activity.

Another study<sup>1</sup> involved 505 sexually active women which were consulted about the experience of coital incontinence. Of these women 56% had coital incontinence. The prevalence of coital intercourse in urinary incontinent women was high. Coital incontinence in these women was associated with abnormal urodynamic diagnosis and urethral dysfunction.

Another study<sup>5</sup>, involved 1,041 women and 53.8% had coital urinary incontinence. From all of these 8% had coital urinary incontinence at penetration, 35% during intercourse, 9% at orgasm, and 48% during a combination of these.

**Table 1. Incidence of CUI in articles reviewed**

Article	Patients	Percent	Mean age
1	505	56%	-
2	Reports about CUI between 1970-2008	10-27 %	53.4
3	97	63.35 %	-
4	Included 26 articles between 1979-2016	24-66 %	-
5	1,041	53.8 %	52.4
6	A database of women with CUI between 1991-2009	11.8%	45.3

CUI: Coital urinary incontinence

## Discussion

The etiology and pathophysiological mechanism underlying the occurrence of coital urinary incontinence have proven to be complex.

In our review of six articles the mean age of appearance was between 45 and 53 years.

Coital urinary incontinence is a complex pathology with a strong negative impact on patients' quality of life. Current studies show a delay in establishing the diagnosis worldwide since the onset of symptoms.

Another purpose of this review was to quantify the percentage of patients who reported coital urinary incontinence. Some studies report prevalence of 11.8%, while other studies report results of over 63%.

In the future, these patients with this specific symptomatology might benefit from therapy (even surgery). This aim is to identify

correctly the population affected, and of course to perform a complete exam, in order to assess the exact pelvic floor disorder responsible for that condition.

### Limitations and future suggestions

The limitation of our study is its low number of articles referring to urinary incontinence during sexual intercourse.

### CONCLUSION

In the present review the prevalence of coital incontinence in urinary incontinent women was high, studies reported high percentage of coital urinary incontinence. We conclude that the disease is under-reported. It can be an embarrassing problem that may lead to reduced sexual desire, reduced ability to achieve an orgasm, and may even be harmful to a relationship, this issue is difficult to understand and research. In fact, it is an underestimated clinical problem.

### Contributions

Concept: B.G.I., R.C., T.E., Design: B.G.I., R.C., T.E., Data Collection or Processing: B.G.I., R.C., T.E., Analysis or Interpretation: B.G.I., R.C., T.E., Literature Search: B.G.I., R.C., T.E., Writing: B.G.I., R.C., T.E.

### Ethics

**Peer-review:** Externally peer-reviewed.

### DISCLOSURES

**Conflict of Interest:** The authors declare no conflict of interest.

**Financial Disclosure:** The authors declared that this study received no financial support.

### REFERENCES

1. Lau HH, Huang WC, Su TH. Urinary leakage during sexual intercourse among women with incontinence: Incidence and risk factors. *PLoS One* 2017; 12: 0177075.
2. Serati M, Salvatore S, Uccella S, Nappi RE, Bolis P. Female urinary incontinence during intercourse: a review on an understudied problem for women's sexuality. *J Sex Med* 2009; 6: 40-8.
3. Grzybowska ME, Wydra DG. Coital incontinence: a factor for deteriorated health-related quality of life and sexual function in women with urodynamic stress urinary incontinence. *Int Urogynecol J* 2017; 28: 697-704.
4. Duralde ER, Rowen TS. Urinary Incontinence and Associated Female Sexual Dysfunction. *Sex Med Rev* 2017; 5: 470-85.
5. Illiano E, Mahfouz W, Giannitsas K, et al. Coital Incontinence in Women With Urinary Incontinence: An International Study. *J Sex Med* 2018; 15: 1456-62.
6. Madhu C, Hashim H, Enki D, Yassin M, Drake M. Coital incontinence: what can we learn from urodynamic assessment? *Urology* 2015; 85: 1034-8.



# Pelvic floor muscle group therapy for the treatment of urinary incontinence during pregnancy and post-partum: a randomized controlled trial

HEIDI F.A. MOOSSDORFF-STEINHAUSER<sup>1</sup>, BARY C.M. BERGHMANS<sup>2</sup>, MARC E.A. SPAANDERMAN<sup>3</sup>,  
ESTHER M.J. BOLS<sup>1</sup>

<sup>1</sup>Department of Epidemiology, Medicine and Life Sciences, Care and Public Health Research Institute (CAPHRI), Maastricht University Faculty of Health, The Netherlands

<sup>2</sup>Maastricht University Medical Centre (MUMC+), Pelvic Care Center, CAPHRI, Maastricht, The Netherlands

<sup>3</sup>Department of Obstetrics and Gynaecology, Maastricht University Medical Centre (MUMC+), Maastricht, The Netherlands

## ABSTRACT

**Objective:** Pelvic Floor Muscle Group Therapy (PFMGT) is an effective treatment option in the general population. However, the effect of therapy during pregnancy and shortly thereafter is unclear. Therefore, this study investigates the effect of PFMGT in peri-partum women with UI compared to care-as-usual.

**Materials and Methods:** Two randomized controlled trials: study 1: pregnant women and study 2: 6 weeks post-partum women, were performed. The primary outcome was UI severity based on the International Consultation on Incontinence Questionnaire-Urinary Incontinence Short form (ICIQ-UI SF). Secondary outcomes were the Global Impression of Severity (GPE) measuring patient's self-reported improvement and the Incontinence Impact Questionnaire-7 (IIQ-7), measuring UI impact. Descriptive and univariate analysis were reported and the non-parametric Mann-Whitney U test was used to compare differences between groups.

**Results:** Inclusion numbers could not be met, and therefore all women received individual Pelvic floor muscles training (PFMT). Study 1 showed no significant results regarding the prevalence of UI (ICIQ-UI SF), GPE and IIQ-7 at any measurement moment. As compared to baseline, study 2 showed a significant improvement for prevalence of UI and impact of UI at 4 months post-partum, however there was no significant difference between groups at other measurement moments. Significant subjective improvement was seen at 4<sup>th</sup> and 9<sup>th</sup> months post-partum, in favor of the PFMT group ( $p=0.02$ ).

**Conclusion:** PFMT, started after childbirth, demonstrated improved UI and quality of life with a lower number of complaints at the 4 months post-partum assessment. However, the full potential of effectiveness of PFMT could not be established due to insufficient inclusions.

**Keywords:** Pelvic floor muscle group therapy; physical therapy; post-partum; pregnancy; pre-partum; urinary incontinence

**Address for Correspondence:** Heidi Moosdorff Steinhauser, Department of Epidemiology, Medicine and Life Sciences, Care and Public Health Research Institute (CAPHRI), Maastricht University Faculty of Health, Netherlands

**E-mail:** heidi.moosdorff@maastrichtuniversity.nl ORCID ID: orcid.org/0000-0002-9651-1731

**Received:** 23 February 2021 **Accepted:** 19 March 2021

©Copyright 2021 by the International Society for Pelviperineology / Pelviperineology published by Galenos Publishing House.

## INTRODUCTION

Urinary incontinence (UI) is the complaint of involuntary loss of urine.<sup>1</sup> The reported overall prevalence of UI varies between 25 and 46.4%.<sup>2,3</sup> Stress urinary incontinence (SUI), the complaint of involuntary loss of urine on effort or physical exertion or on sneezing or coughing,<sup>1</sup> is the most prevalent type among peripartum women.<sup>2-4</sup> During pregnancy prevalence of UI is reported between 9 and 75%, and post-partum between 10 and 63%.<sup>5-8</sup> UI reduces quality of life (QoL) but nonetheless, many women tend to accept their problems because they are embarrassed, think it is normal and will diminish by itself.<sup>8-10</sup>

The development of UI peri-partum might be due to several reasons, including childbirth or physiological weight gain resulting in an increase of intra-abdominal pressure transmitted to the bladder and bladder neck, leading to urethral mobility and pelvic floor muscles (PFM) activity problems.<sup>11-13</sup> The PFMs of women with UI during pregnancy are weaker and thinner.<sup>14</sup>

PFM training (PFMT) aims to improve the supportive system and is a first-line treatment option for UI.<sup>15,16</sup> As the costs for healthcare are rising, it is important to provide cost-effective therapies.<sup>17</sup> PFMT can be provided as individual, but also as group therapy (PFMGT). PFMGT appeared to be equally effective in the treatment of UI in women in the general or older population.<sup>18,19</sup> A recent Cochrane systematic review concluded that it is uncertain whether PFMT is an effective treatment option for women with UI during pregnancy and post-partum.<sup>20</sup> Also, information on cost-effectiveness of PFMT and long-term effects is lacking.<sup>20</sup>

Therefore, the primary aim of this study was to investigate whether a structured assessment and treatment program of intensive, supervised PFMGT, including a home maintenance program, reduces 18 months post-partum UI severity (frequency, amount, and impact) compared to care-as usual (CAU) in adult pregnant (study 1) and post-partum women with SUI (study 2). The secondary aim was to investigate whether PFMGT is cost-effective compared to CAU.

## MATERIALS AND METHODS

### Study design

In two randomized controlled multicenter trials, PFMGT (intervention group) was compared to CAU (control group). The two studies were registered as one trial in The Netherlands National Trial Register (NTR5971). The Medical Ethics Committee (METC) of the Maastricht University Medical Center (MUMC+) has approved study 1 (METC162038) and study 2 (METC162051). The ethics boards of the participating four hospitals, Zuyderland Medical Center (two locations), Laurentius hospital and Maxima Medical Center, approved the trial, indicating also coverage for 13 local midwifery practices. The study protocol was published previously.<sup>21</sup>

### Participants

The women were recruited in the southern part of The Netherlands between December 1<sup>st</sup> 2017 and August 1<sup>st</sup> 2019 by midwives and physicians (case managers). Women were included if they met amongst others the following criteria: (1)  $\geq 18$  years, (2) UI (stress or mixed with predominant SUI factor, according to Haylen et al.<sup>22</sup>), and (3) a score of  $>3$  on the International Consultation on Incontinence Questionnaire-Urinary Incontinence Short Form (ICIQ-UI SF).<sup>23</sup> Exclusion criteria included: (1) UI prior to first pregnancy, still existing during pregnancy, (2) high-risk pregnancy, resulting in a contra-indication for performing intensive PFMT (e.g., placenta praevia, vaginal blood loss, preterm uterine contractions), (3) suffering from significant exercise limitations or co-morbidities (physical or psychological) that would restrain a woman from participation in the group therapy. A full description of inclusion and exclusion criteria is published elsewhere.<sup>21</sup>

### Randomization and blinding

During a regular planned consultation with their case manager, women meeting the eligibility criteria and interested to participate, received a short vaginal examination to check the ability to contract the PFMs. The candidate participant received an email with a link to the electronic baseline questionnaire after signing the informed consent. Once the questionnaires were completed, blocked randomisation was done by a computer-generated sequence in a 1:1 ratio on patient and location level. Allocation in blocks of four was concealed and done using a central computer. Participants in the intervention group, who could not contract their PFMs correctly, were referred to a specialized (pelvic) physical therapist (PT) for individual instruction before joining PFMGT (Figure 1).

The participants, specialized PT and coordinating researcher could not be blinded. However, once the participant completed the questionnaires, they were blocked from making alterations. Before the statistical analyses all participants were appointed a new study number for which the coordinating researcher was blinded. Therefore, analyses were done blinded for treatment allocation.

### Intervention

The intervention was provided by one specialized PT in every region. In Netherlands, pelvic PT is a specialisation within the field of physical therapy and has its own registration in order to guarantee quality.<sup>24</sup> The specialized PT's were instructed on the PFMGT protocol which consisted of eight once weekly PFMGT sessions of 60 minutes each. Pregnant and post-partum women

could participate as soon as they were randomized in the same intervention group, with a maximum of four per group.

The intervention included instructions on pelvic floor anatomy and how to contract, relax and train the PFMs correctly in combination with general physical exercises with a strong focus

on self-management. The PFMGT protocol has been published previously.<sup>21</sup> The women in the intervention group received a mApp (iPelvis),<sup>25</sup> which is an application with individualized pelvic PT exercises to reinforce adherence to and compliance with a home maintenance program.

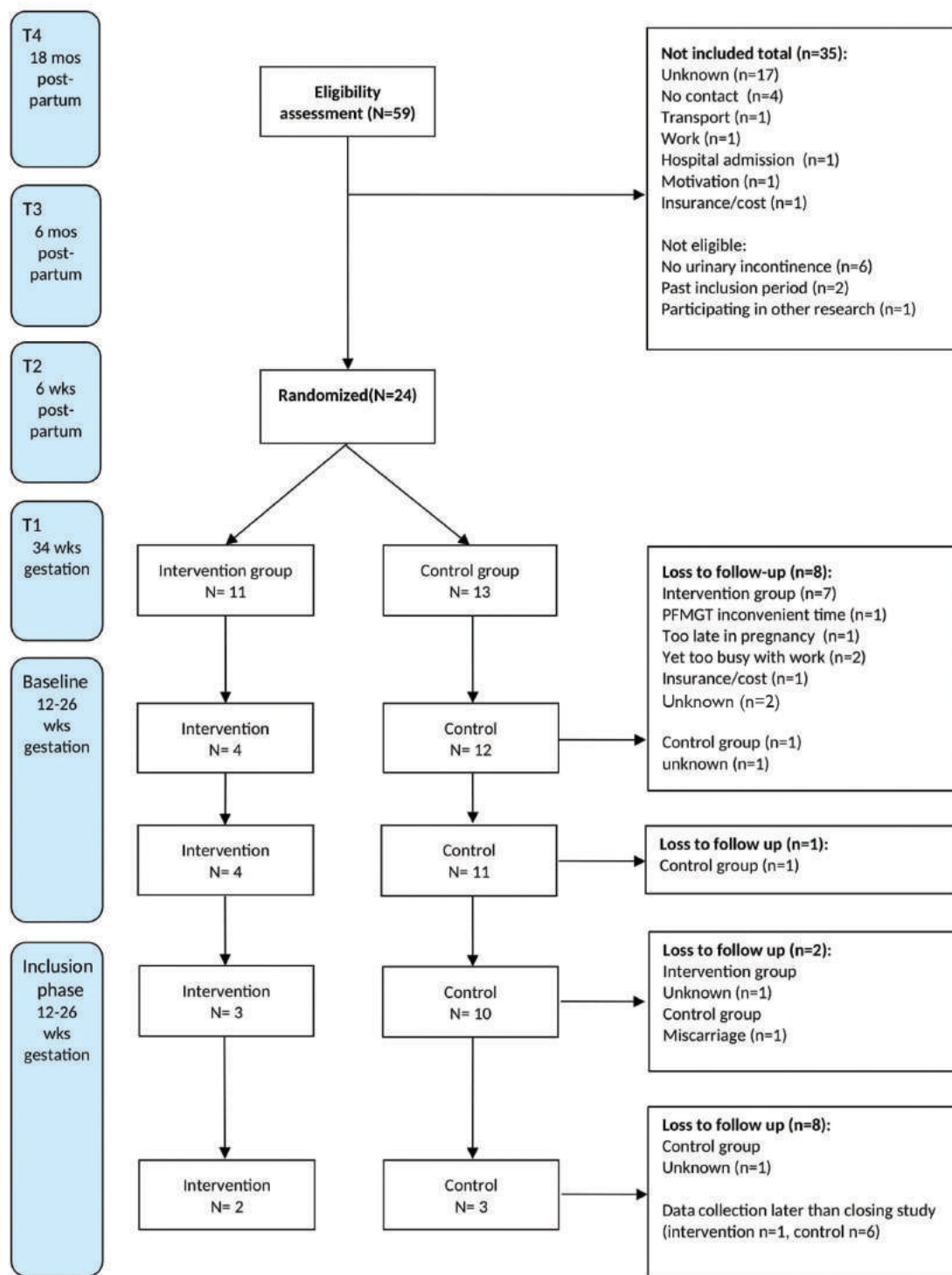

Figure 1. Flowchart study 1

T: measurement, wks: weeks, mos: months, N: number, PFMGT: pelvic floor muscle group therapy

## Care-as-usual

Participants in the CAU group received regular advice from their case managers and were free to participate in any pregnancy-related course or visit a health care professional for their UI.

## Measurements

Besides the measurement of the baseline characteristics in both studies the women were asked to fill in the questionnaires multiple times (Figure 1 and 2).

## Primary outcome measure

The primary outcome is based on the ICIQ-UI SF. This is a validated brief (four questions) measure for evaluating the frequency, severity and impact on QoL of UI.<sup>26</sup> The total score ranges from 0 (not affected) to 21 (severely affected). The questionnaire is translated in Dutch.<sup>27</sup> Therapy success is defined as absence of UI or change from baseline of at least three points on the ICIQ-UI SF at 18 months post-partum.<sup>28</sup>

## Secondary outcome measures

The Patient Global Impression of Severity (GPE) questionnaire was used to assess the patients' self-reported improvement.<sup>29</sup> It is a reliable scale for incontinence, consisting of one question and seven response options ranging from very much improved to very much deterioration.<sup>30,31</sup>

The validated Incontinence Impact Questionnaire-7 (IIQ-7) was used to determine the UI impact on four domains: mobility, physical functioning, emotional health and embarrassment.<sup>32</sup> The total score ranges from 0 to 100, 0 meaning no impact and 100 extreme impact.

## Sample size

The total sample size estimate for study 1 was 150, and study 2 was 90. These numbers are based on a significance level of 0.05, a power of 90%, and a 20% drop-out rate. Further justification has been described elsewhere.<sup>21</sup>

## Statistical analysis

The Consolidated Standards of Reporting Trials (CONSORT) statement was followed for reporting the trial.<sup>33</sup> Data was analysed according to the intention-to-treat principle.

Descriptive and univariate analysis were reported as means and standard deviations or 95% confidence intervals. The non-parametric Mann-Whitney U test was performed to compare differences between the two groups. A p-value <0.05 is considered to be statistically significant. Data analyses are carried out using IBM SPSS Statistics for Windows, version 25.0 (IBM Corp., Armonk, N.Y., USA).

## RESULTS

Recruitment took place between 01.06.2017 and 01.08.2019.

## Participants

In study 1, 59 women were eligible for participation, of which 24 women were randomized (intervention group=11, control group=13) (Figure 1). Four participants completed the study (Figure 1). In study 2, 116 women were eligible of which 23 were randomized (intervention group=10, control group=13), 14 participants completed the study (Figure 2). Characteristics of the participants for study 1 and 2 are shown in Table 1.

## Outcomes

The results are based on individual PFMT instead of PFMGT, as groups did not fill sufficiently (therefore, from this point on the term PFMT will be used). However, the original PFMGT protocol was followed. Study 1 showed no statistically significant differences between groups at any point regarding the ICIQ-UI SF total score, GPE and IIQ-7 (Table 2), although both groups showed improvements on all outcomes post-intervention.

In study 2, the intervention group improved significantly compared to the control group ( $p=0.012$ ) at four months post-partum with regard to the ICIQ-UI SF score of ( $p=0.012$ ) and IIQ-7 ( $p=0.04$ ). Moreover, the GPE of the intervention group improved significantly at T1 and T2 ( $p=0.02$ ). T3 showed no statistically significant difference between groups (Table 2).

The mean number of days per week the participants performed PFM exercises during the eighth week PFMGT was 5.9 (median 6.0) and 5.0 (median 5.3) in study 1 and 2, respectively.

Cost-effectiveness outcomes have not been calculated because both studies were underpowered.

## DISCUSSION

The cost-effectiveness of PFMT, for pregnant (study 1) and post-partum women (study 2) with SUI could not be established as planned, due to the small number of included women in both studies. As a consequence of the small numbers, all women in the intervention group received individual PFMT. Therefore, the reported results should be interpreted with great caution and no conclusions regarding the original hypothesis can be made.

PFMT started during pregnancy showed no significant results regarding the effect on UI, impact, and self-perceived impression of severity of symptoms at any point. This is in line with a recent Cochrane systematic review, reporting no evidence of the treatment effect of PFMT on UI in late pregnancy.<sup>20</sup> Most likely our findings must be explained by the fact the study is underpowered. In addition, during pregnancy the continence

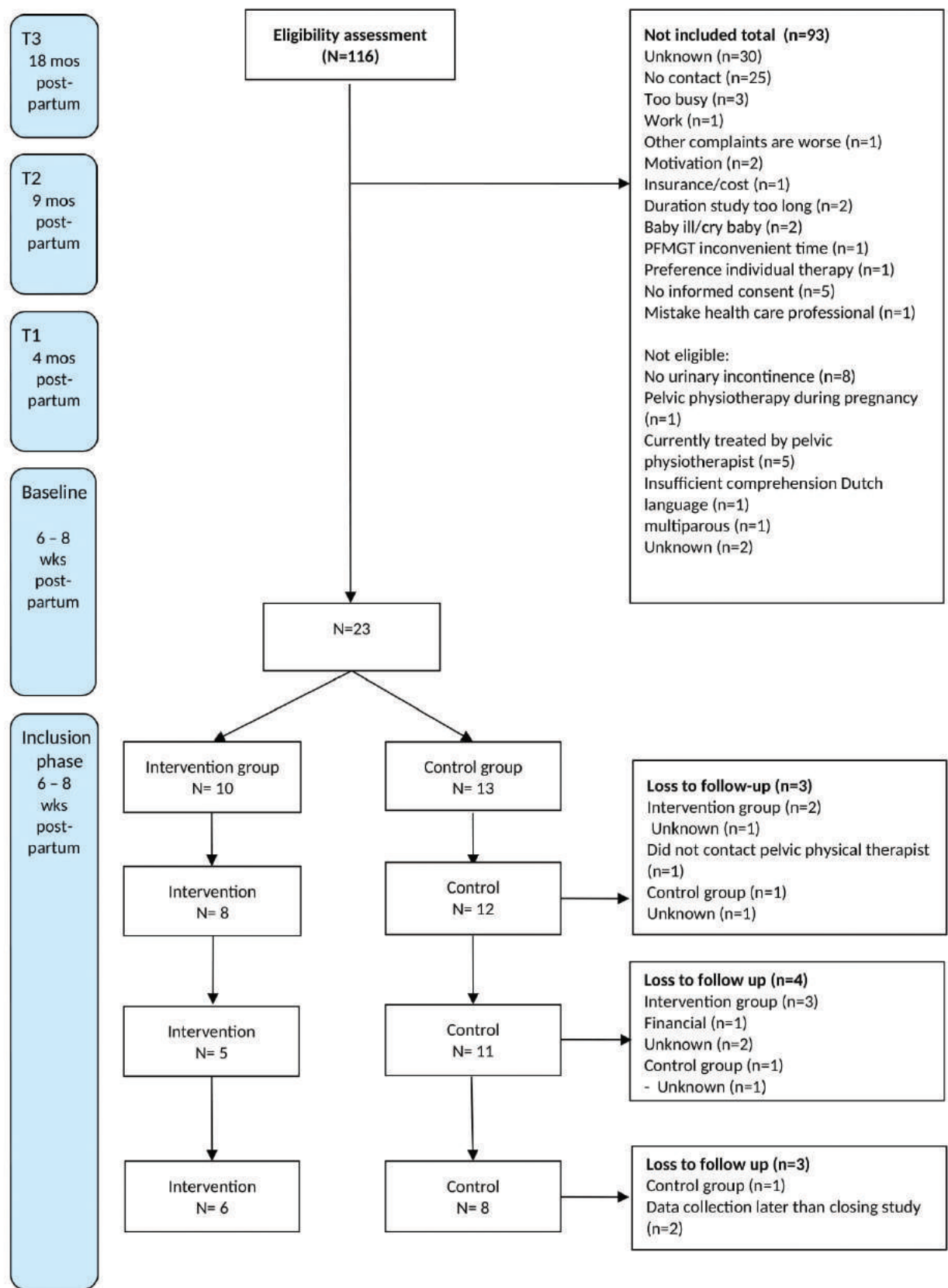

Figure 2. Flowchart study 2

T: measurement, wks: weeks, mos: months, PFMGT: pelvic floor muscle group therapy

mechanism is challenged by a multitude of factors of which some are non-modifiable. Physiological weight gain,<sup>2</sup> and changes in the neuromuscular function of the urethral sphincter are considered examples of non-modifiable factors.<sup>34</sup> However, PFMT in the general female population is a proven effective intervention.<sup>35</sup>

PFMT post-partum revealed a positive effect directly after PFMT regarding UI, impact and self-perceived impression of severity. However, this effect was not maintained at later follow-up, except for subjective improvement. Although this study focused on adherence strategies for PFMT, the effect did not last.

**Table 1. Participants' characteristics**

	Study 1 n (%)			Study 2 n (%)			
	I (11)	C (13)	Total (24)	I (10)	C (13)	Total (23)	
Age (mean, range)	32.1 (24-38)	32.9 (23-42)	32.5 (23-42)	32.3 (27-37)	30.2 (24-37)	31.0 (24-37)	
Education	Secondary	4 (36.4)	4 (30.8)	8 (33.3)	3 (30.0)	5 (38.5)	8 (34.8)
	Tertiary	7 (63.6)	9 (69.2)	16 (66.7)	7 (70.0)	8 (61.5)	15 (65.2)
Parity	0	4 (36.4)	4 (30.8)	8 (33.3)	-	-	-
	1	7 (63.6)	7 (53.8)	14 (58.3)	2 (20.0)	5 (38.5)	7
	≥2	0 (0)	2 (15.4)	2 (4.2)	1 (10.0)	1 (7.7)	2
	Missing				7	7	14

n: number, I: intervention group, C: control group

**Table 2. Results ICIQ-UI SF, GPE and IIQ-7**

Study 1	Baseline 12-26 weeks gestation			T1			T2			T3		
				34 weeks gestation			6 weeks post-partum			6 months post-partum		
	I (11)	C (13)	T (24)	I (4)	C (12)	T (16)	I (4)	C (11)	T (15)	I (3)	C (10)	T (13)
ICIQ-UI SF (range 0-21)	11.2 (2.0) (8-14)	9.5 (3.2) (5-15)	10.3 (2.8) (5-15) p=0.17 <sup>∅</sup>	6.8 (2.2) (4-9)	8.6 (3.8) (4-14)	8.1 (3.5) (4-14) p=0.46	6.8 (2.2) (4-9)	6.1 (3.9) (0-11)	6.3 (3.5) (0-11) p=0.84	7.3 (1.5) (6-9)	5.9 (3.8) (0-11)	6.2 (3.4) (0-11) p=0.67
GPE (range: 1-7)	-	-	-	2.3 (0.3)	3.5 (0.5)	3.2 (1.5) p=0.10	2.8 (1.7)	2.6 (1.5)	2.7 (1.5) p=0.89	3.3 (1.5)	2.9 (1.1)	3.0 (1.2) p=0.66
IIQ-7 (range: 0 - 100)	14.3 (0-57.1)	16.8 (0-57.1)	p=0.84	13.1 (0-19.0)	15.9 (0-57.1)	p=0.95	10.7 (0-28.5)	9.9 (0-38.1)	p=0.74	7.9 (0-14.3)	4.8 (0-23.8)	p=0.40
Study 2	Baseline 6 weeks post-partum			4 months post-partum			9 months post-partum			18 months post-partum		
	I (10)	C (13)	T (23)	I (8)	C (12)	T (20)	I (5)	C (11)	T (16)	I (6)	C (8)	T (14)
ICIQ-UI SF (range: 0-21)	8.3 (1.9) (5-11)	8.6 (2.5) (6-13)	8.5 (2.2) (5-13) p=0.88	5.3 (3.0) (0-11)	8.7 (2.9) (5-13)	7.2 (3.3) (0-13) p=0.01*	4.2 (2.6) (1-8)	7.5 (3.8) (0-13)	6.4 (3.7) (0-13) p=0.09	4.3 (5.2) (0-13)	8.4 (3.6) (1-12)	6.6 (4.7) (0-13) p=0.14
GPE (range: 1-7)	-	-	-	2.3 (0.89)	3.3 (0.99)	2.90 (1.07) p=0.02*	2.00 (0.71)	3.55 (1.21)	3.06 (1.29) p=0.02*	2.0 (1.55)	3.63 (1.30)	2.93 (1.59) p=0.08
IIQ-7 (range: 0 - 100)	14.3 (0-38.1)	19.1 (0-57.1)	p=0.90	6.0 (0-19.1)	23.0 (0-57.1)	p=0.04*	13.3 (0-47.6)	20.3 (0-66.7)	p=.32	7.1 (0-33.3)	18.5 (0-47.6)	p=0.09

I: Intervention group, C: Control group; T: Total group, T1: Follow-up 1; T2: Follow-up 2; T3: Follow-up 3; T4: Follow-up 4; ICIQ-UI SF: International Consultation on Incontinence Questionnaire-Urinary Incontinence Short Form; GPE: Global perceived effect; IIQ-7: Incontinence Impact Questionnaire-7; \*: significant, ∅: between groups.



We anticipated no major problems in recruiting the necessary number of participants for both studies due to a number of reasons. Firstly, the recruitment was done by case managers covering the majority of maternal care (pre- and post-partum care) in the southern part of The Netherlands, in which over 8,500 babies were born in 2019.<sup>17</sup> Secondly, high prevalence rates of SUI during pregnancy and post-partum are reported in numerous studies and thirdly,<sup>6,8</sup> other studies on PFMT peri-partum in northern Europe reported high inclusion and participation rates.<sup>36</sup> Nonetheless, recruitment proved to be problematic.

In order to improve the number of inclusions several alterations to the eligibility criteria of the study were proposed and granted. The changes were: 1. inclusion of all women regardless of parity instead of only primigravid and primiparous women. 2. extending the inclusion period from 12 to 20 weeks up to 26 weeks of gestation. Other strategies to improve the inclusion rate were: regular presentations in the participating hospitals, visits to midwifery practices, attending clinics and regular phone conversations with midwives and research assistants of the hospitals. Also, a monthly newsletter informing the healthcare professionals was sent.

Several factors might explain the disappointing inclusion numbers, which might also be useful for other researchers in the field to plan their studies or optimize their recruitment strategies. Firstly, our studies were so called 'efficiency studies' in which two different treatments are compared with regard to effect and financial costs, with the objective to discourage use of inefficient interventions.<sup>37</sup> Due to this design, participants were only allowed to be included by a case manager like a midwife or obstetrician, which might have influenced the disappointing inclusion numbers. In the study of Mørkved et al.<sup>36</sup> on the effect of PFMT to prevent UI during pregnancy, all women were asked to participate through a letter which they received in combination with the invitation for their standard appointment with their case manager. Secondly, a standard question on UI is lacking in electronic patient following systems in The Netherlands for case managers reporting peri-partum care. This digital reminder to ask for UI might have influenced the inclusion numbers. Thirdly, case managers involved in these studies mentioned their lack of attention as a major barrier to recruit participants together with lack of time and a difficult to implement protocol in usual clinical practice. These are well known barriers in clinical research.<sup>38,39</sup> Moreover, the case managers also mentioned that the standard internal assessment of the PFM in the protocol was a barrier due to lack of time. The number of drop-outs in study 1, once randomized, and in the initial inclusion phase in study 2, can be explained by known barriers for patient participation

like inconvenience due to extra appointments, travel problems, costs and a preference for a specific study arm.

Fourth, the sample size calculation for both studies was based on reported high UI prevalence numbers. However, the experienced bother was not taken into account. This might have resulted in an overestimation of the crude prevalence of UI, because level of experienced bother is associated with help-seeking behavior.<sup>40</sup> Our result regarding PFMT post-partum may justify and therefore support the recommendation of Woodley et al.<sup>20</sup> for the development of a new RCT on this subject. However, it is advisable to recruit women through for instance (social) media because questions on UI are not standardly asked by health care professionals.<sup>41</sup>

Strengths of this study include that the intervention offered in both studies is protocol- and evidence based and the ability to contract the PFM is checked.<sup>21</sup> Women who did not know how to contract the PFM received an individual session by a specialized PT in order to learn how to contract and relax, before joining PFMT; in addition to the protocol has a strong emphasis on adherence with the use of a mApp. A mApp has shown to have a beneficial effect on adherence.<sup>42,43</sup> The original design includes a long follow-up period and cost-effectiveness calculation.

In conclusion, PFMT, started post-partum, demonstrated statistically significant improvements in UI and QoL with a lower number of complaints at the 4 months post-partum assessment. However, the full potential of effectiveness of PFMGT could not be established due to insufficient inclusions, the latter most likely due to accepted bother from UI rather than the presence of UI itself.

## Acknowledgements

We would like to thank all case managers for recruiting participants and all pelvic physical therapists for the treatment of participants. We also thank Mrs. Julia H. Herbert for checking the English language.

## Contributions

Surgical and Medical Practices: H.F.A.M., E.M.J.B., B.C.M.B., Concept: B.C.M.B., M.E.A.S., Design: H.F.A.M., E.M.J.B., M.E.A.S., B.C.M.B., Data Collection or Processing: H.F.A.M., E.M.J.B., Analysis or Interpretation: H.F.A.M., E.M.J.B., Literature Search: H.F.A.M., Writing: H.F.A.M., E.M.J.B., B.C.M.B., M.E.A.S.

## Ethics

**Ethics Committee Approval:** This study was approved by Maastricht University (no: METC162038).

**Informed Consent:** Informed consent was obtained.

**Peer-review:** Externally peer-reviewed.

## DISCLOSURES

**Conflict of Interest:** No conflict of interest was declared by the authors

**Financial Disclosure:** ZonMw (The Netherlands Organisation for Health Research and Development, file number: 80-84300-98-72001). The fund had no role in study design, subject enrollment, or data analysis.

## REFERENCES

- D'Ancona C, Haylen B, Oelke M, et al. The International Continence Society (ICS) report on the terminology for adult male lower urinary tract and pelvic floor symptoms and dysfunction. *Neurourol Urodyn* 2019; 38: 433-77.
- Schreiber Pedersen L, Lose G, Høybye MT, Elsner S, Waldmann A, Rudnicki M. Prevalence of urinary incontinence among women and analysis of potential risk factors in Germany and Denmark. *Acta Obstet Gynecol Scand* 2017; 96: 939-48.
- Hannestad YS, Rortveit G, Sandvik H, Hunskaar S; Norwegian EPINCONT study. Epidemiology of Incontinence in the County of Nord-Trøndelag. A community-based epidemiological survey of female urinary incontinence: the Norwegian EPINCONT study. *Epidemiology of Incontinence in the County of Nord-Trøndelag. J Clin Epidemiol* 2000; 53: 1150-7.
- Botlero R, Davis SR, Urquhart DM, Shortreed S, Bell RJ. Age-specific prevalence of, and factors associated with, different types of urinary incontinence in community-dwelling Australian women assessed with a validated questionnaire. *Maturitas* 2009; 62: 134-9.
- Højberg KE, Salvig JD, Winsløw NA, Lose G, Secher NJ. Urinary incontinence: prevalence and risk factors at 16 weeks of gestation. *Br J Obstet Gynaecol* 1999; 106: 842-50.
- Nigam A, Ahmad A, Gaur D, Elahi A, Batra S. Prevalence and risk factors for urinary incontinence in pregnant women in late third trimester. *IJRCOG* 2016; 5: 2187-91.
- Rikard-Bell J, Iyer J, Rane A. Perineal outcome and the risk of pelvic floor dysfunction: a cohort study of primiparous women. *Aust N Z J Obstet Gynaecol* 2014; 54: 371-6.
- Moosdorff-Steinhaus HFA, Berghmans BCM, Spaanderman MEA, Bols EMJ. Urinary incontinence during pregnancy: prevalence, experience of bother, beliefs, and help-seeking behavior. *Int Urogynecol J* 2021; 32: 695-701.
- Buurman MB, Lagro-Janssen AL. Women's perception of postpartum pelvic floor dysfunction and their help-seeking behaviour: a qualitative interview study. *Scand J Caring Sci* 2013; 27: 406-13.
- Mason L, Glenn S, Walton I, Hughes C. Women's reluctance to seek help for stress incontinence during pregnancy and following childbirth. *Midwifery* 2001; 17: 212-21.
- Swenson CW, Kolenic GE, Trowbridge ER, et al. Obesity and stress urinary incontinence in women: compromised continence mechanism or excess bladder pressure during cough? *Int Urogynecol J* 2017; 28: 1377-85.
- DeLancey JO, Kearney R, Chou Q, Speights S, Binno S. The appearance of levator ani muscle abnormalities in magnetic resonance images after vaginal delivery. *Obstet Gynecol* 2003; 101: 46-53.
- MacLennan AH, Taylor AW, Wilson DH, Wilson D. The prevalence of pelvic floor disorders and their relationship to gender, age, parity and mode of delivery. *BJOG* 2000; 107: 1460-70.
- Mørkved S, Salvesen KA, Bø K, Eik-Nes S. Pelvic floor muscle strength and thickness in continent and incontinent nulliparous pregnant women. *Int Urogynecol J Pelvic Floor Dysfunct* 2004; 15: 384-9.
- NICE. Urinary incontinence in women: management (cg 171). 2013; <https://www.nhs.uk/media/251043/nice-guideline-urinary-incontinence-in-women-management.pdf> (Accessed 2 May 2020).
- Kobashi K, Albo M, Dmochowski R, et al. Surgical Treatment of Female Stress Urinary Incontinence: AUA/SUFU Guideline. *The Journal of Urology* 2017; 198: 875-83.
- CBS Statline. Geboorte; kerncijfers vruchtbaarheid, leeftijd moeder, regio. 2020 29 June 2020. <https://opendata.cbs.nl/statline/?themaNr=82388#/CBS/nl/dataset/37201/table?ts=1599385813955>
- Paiva LL, Ferla L, Darski C, Catarino BM, Ramos JG. Pelvic floor muscle training in groups versus individual or home treatment of women with urinary incontinence: systematic review and meta-analysis. *Int Urogynecol J* 2017; 28: 351-9.
- Dumoulin C, Morin M, Danieli C, et al. Group-Based vs Individual Pelvic Floor Muscle Training to Treat Urinary Incontinence in Older Women: A Randomized Clinical Trial. *JAMA Intern Med* 2020; 180: 1284-93.
- Woodley SJ, Lawrenson P, Boyle R, et al. Pelvic floor muscle training for preventing and treating urinary and faecal incontinence in antenatal and postnatal women. *Cochrane Database Syst Rev* 2020; 5: CD007471.
- Moosdorff-Steinhaus HFA, Bols EMJ, Spaanderman MEA, et al. Long-term effects of motherfit group therapy in pre-(MOTHERFIT1) and post-partum women (MOTHERFIT2) with stress urinary incontinence compared to care-as-usual: study protocol of two multi-centred, randomised controlled trials. *Trials* 2019; 20: 237.
- Haylen BT, de Ridder D, Freeman RM, et al. An International Urogynecological Association (IUGA)/International Continence Society (ICS) joint report on the terminology for female pelvic floor dysfunction. *Int Urogynecol J* 2010; 21: 5-26.
- Timmermans L, Falez F, Mélot C, Wespes E. Validation of use of the International Consultation on Incontinence Questionnaire-Urinary Incontinence-Short Form (ICI-Q-UI-SF) for impairment rating: a transversal retrospective study of 120 patients. *Neurourol Urodyn* 2013; 32: 974-9.
- Westerik-Verschuuren L, Moosdorff-Steinhaus H. Beroepsprofiel bekkenfysiotherapeut. *KNGF Augustus* 2014; 1-59.

25. Latorre GFS, de Fraga R, Seleme MR, Mueller CV, Berghmans B. An ideal e-health system for pelvic floor muscle training adherence: Systematic review. *Neurourol Urodyn* 2019; 38: 63-80.
26. Avery K, Donovan J, Peters TJ, Shaw C, Gotoh M, Abrams P. ICIQ: a brief and robust measure for evaluating the symptoms and impact of urinary incontinence. *Neurourol Urodyn* 2004; 23: 322-30.
27. Grzybowska ME, Wydra D. 24/7 usage of continence pads and quality of life impairment in women with urinary incontinence. *Int J Clin Pract* 2019; 73: e13267.
28. Nyström E, Sjöström M, Stenlund H, Samuelsson E. ICIQ symptom and quality of life instruments measure clinically relevant improvements in women with stress urinary incontinence. *Neurourol Urodyn* 2015; 34: 747-51.
29. Hudak PL, Wright JG. The characteristics of patient satisfaction measures. *Spine (Phila Pa 1976)* 2000; 25: 3167-77.
30. Kamper SJ, Ostelo RW, Knol DL, Maher CG, de Vet HC, Hancock MJ. Global Perceived Effect scales provided reliable assessments of health transition in people with musculoskeletal disorders, but ratings are strongly influenced by current status. *J Clin Epidemiol* 2010; 63: 760-6.e1.
31. Yalcin I, Bump RC. Validation of two global impression questionnaires for incontinence. *Am J Obstet Gynecol* 2003; 189: 98-101.
32. Utomo E, Korfage IJ, Wildhagen MF, Steensma AB, Bangma CH, Blok BF. Validation of the Urogenital Distress Inventory (UDI-6) and Incontinence Impact Questionnaire (IIQ-7) in a Dutch population. *Neurourol Urodyn* 2015; 34: 24-31.
33. Boutron I, Altman DG, Moher D, Schulz KF, Ravaud P; CONSORT NPT Group. CONSORT Statement for Randomized Trials of Nonpharmacologic Treatments: A 2017 Update and a CONSORT Extension for Nonpharmacologic Trial Abstracts. *Ann Intern Med* 2017; 167: 40-7.
34. Weidner AC, South MM, Sanders DB, Stinnett SS. Change in urethral sphincter neuromuscular function during pregnancy persists after delivery. *Am J Obstet Gynecol* 2009; 201: 529.e1-6.
35. Dumoulin C, Cacciari LP, Hay-Smith EJC. Pelvic floor muscle training versus no treatment, or inactive control treatments, for urinary incontinence in women. *Cochrane Database Syst Rev* 2018; 10: CD005654.
36. Mørkved S, Bø K, Schei B, Salvesen KA. Pelvic floor muscle training during pregnancy to prevent urinary incontinence: a single-blind randomized controlled trial. *Obstet Gynecol* 2003; 101: 313-9.
37. ZonMw. Research and results/efficiency studies. <https://www.zonmw.nl/en/research-and-results/efficiency-studies/#:~:text=Efficiency%20Studies%20provide%20the%20evidence,%2C%20researchers%2C%20practitioners%20and%20policymakers> (Accessed 20 October, 2020).
38. Ross S, Grant A, Counsell C, Gillespie W, Russell I, Prescott R. Barriers to participation in randomised controlled trials: a systematic review. *J Clin Epidemiol* 1999; 52: 1143-56.
39. Isaksson E, Wester P, Laska AC, Näsman P, Lundström E. Identifying important barriers to recruitment of patients in randomised clinical studies using a questionnaire for study personnel. *Trials* 2019; 20: 618.
40. Monz B, Chartier-Kastler E, Hampel C, et al. Patient characteristics associated with quality of life in European women seeking treatment for urinary incontinence: results from PURE. *Eur Urol* 2007; 51: 1073-81.
41. National Institute for health and care excellence (NICE). Antenatal care for uncomplicated pregnancies (CG62). 2008; <https://www.nice.org.uk/guidance/cg62/resources/antenatal-care-for-uncomplicated-pregnancies-pdf-975564597445> (Accessed 8 February, 2021).
42. Bernard S, Boucher S, McLean L, Moffet H. Mobile technologies for the conservative self-management of urinary incontinence: a systematic scoping review. *Int Urogynecol J* 2020; 31: 1163-74.
43. Araujo CC, Marques AA, Juliato CRT. The adherence of home pelvic floor muscles training using a mobile device application for women with urinary incontinence: a randomized controlled trial. *Female Pelvic Med Reconstr Surg* 2020; 26: 697-703.



# Clinical and subjective outcomes of abdominal mesh surgery (sacrocolpopexy and sacrohysteropexy) for apical prolapse: a single-center experience

MONIKA ANANT<sup>1</sup>, AMRITA SINGH<sup>2</sup>, SHWETA GUPTA<sup>3</sup>, MUKTA AGARWAL<sup>1</sup>, SANGAM KUMARI<sup>1</sup>, ANITA PASWAN<sup>1</sup>

<sup>1</sup>Department of Obstetrics and Gynaecology, All India Institute of Medical Sciences-Patna, Patna, India

<sup>2</sup>Department of Obstetrics and Gynaecology, Pristyn Care, New Delhi, India

<sup>3</sup>Department of Obstetrics and Gynaecology, Anugrah Narayan Magadh Medical College (ANMCH), Gaya, India

## ABSTRACT

**Objective:** Apical compartment prolapse affects the day-to-day activities while decreasing the quality of life of affected women. With better anatomical understanding of the supports of pelvic organs and increasing life expectancy of women, reconstructive pelvic surgeries may be offered to all. Restoration of anatomical positions of displaced pelvic organs can be achieved either by open abdominal, laparoscopic or vaginal suspension procedures.

The aim of the study was to assess the perioperative and short term (6–24 months) post-operative success rates, complications and subjective satisfaction of women undergoing apical prolapse surgery by abdominal sacrohysteropexy for uterine prolapse and sacrocolpopexy for vault prolapse.

**Materials and Methods:** A prospective observational study of 41 patients who underwent abdominal mesh surgery for apical prolapse, during 2016–2018, in a tertiary hospital of eastern India. These patients were followed up for over a 2 years period, to assess the outcome measures.

**Results:** Mean follow up of patients was 18.3 months with apical success rates (defined as Pelvic Organ Prolapse Quantifications System staging of 0/1 post-surgery) of 100% (mean point C -6.55 and mean point D - 8.8). Intraoperative complications encountered were bladder injury and hemorrhage. No mesh complications occurred during the study period. A significant reduction in the subjective scores of vaginal symptoms, sexual wellbeing and quality of life was also noted in study participants.

**Conclusion:** Abdominal sacrocolpopexy and sacrohysteropexy showed excellent anatomical success rates as per results of this study. They provide optimum apical support with a good functional outcome for patients with vaginal apical prolapse.

**Keywords:** Apical prolapse; sacrocolpopexy; abdominal; mesh

## INTRODUCTION

Pelvic organ prolapse (POP) is the descent of one or more of the pelvic structures (bladder, uterus, bowel) from their normal

anatomic location towards or through the vaginal opening. Most often POP requires surgical treatment. Women have an 11 percent chance of undergoing surgery for POP by 80 years of age.<sup>1,2</sup> Women of all ages may be affected, although pelvic

**Address for Correspondence:** Monika Anant, Department of Obstetrics Gynaecology, All India Institute of Medical Sciences-Patna, Patna, India

**E-mail:** drmonika.anant@gmail.com ORCID ID: orcid.org/0000-0001-7957-379X

**Received:** 08 February 2021 **Accepted:** 15 April 2021

©Copyright 2021 by the International Society for Pelviperineology / Pelviperineology published by Galenos Publishing House.

organ prolapse is more common in older women. The etiology is multifactorial resulting in the loss of pelvic support by either a direct injury to the levator ani muscle forming the pelvic basin or neurologic injury to pudendal nerves during vaginal childbirth. Previous hysterectomy for POP and an increased intra-abdominal pressure from chronic coughing, straining with constipation, or repeated heavy weight lifting are the contributory factors.

Apical compartment prolapse occurs when the vaginal cuff/apex of hysterectomised patients descends down or out through the vagina. This may or may not be associated with anterior (cystocele, urethrocele) or posterior vaginal wall (enterocele, rectocele) prolapse. Vaginal vault prolapse is defined as the descent of the vaginal cuff below a point that is 2 cm less than the total vaginal length above the plane of the hymen by the International Continence Society.<sup>3</sup> Urinary, anorectal, and coital dysfunction may be associated with the prolapse and can affect a women's quality of life negatively.<sup>4</sup>

Surgical options for vault prolapse are reconstructive and obliterative. Abdominal (sacrocolpopexy) and vaginal [sacrospinous fixation (SSF)] are commonly performed reconstructive procedures. In abdominal sacrocolpopexy (ASCP), whether open (OSCP) or laparoscopic (LSCP), a graft material is attached between the vagina and sacrum, supporting the vagina, thereby restoring pelvic anatomy. ASCP is the most durable operation for advanced POP and serves as the criterion (gold) standard against which other operations are compared.<sup>5,6</sup> However, data on long-term (5 to 10 years) durability of sacrocolpopexy are limited as most studies have reported short term outcomes.

For younger women with POP wishing to become pregnant again, suspension of the uterus can be done by various routes and to different pelvic structures. Operative procedures are ventral hysteropexy (undersurface of the abdominal wall), transvaginal uterosacral SSF, and laparoscopic uterine suspension by suturing round ligaments to the rectus sheath. Sacrohysteropexy attaches a mesh from anterior and posterior cervix at the level of the isthmus to the anterior longitudinal ligament overlying the sacrum retroperitoneally.

Most of the published literature on sacrocolpopexy and sacrohysteropexy are retrospective studies where objective anatomical and surgical outcomes have been dealt with.<sup>7</sup> The functional component (vaginal symptoms, sexual wellbeing) of prolapse surgery has often been neglected. This article deals with short term operative and anatomical outcome (6–24 months) of open sacrocolpopexy and sacrohysteropexy along with the subjective outcome of vaginal symptoms and sexual wellbeing of females.

## MATERIALS AND METHODS

A prospective observational study was undertaken at the Department of Obstetrics and Gynaecology of a tertiary level hospital after clearance from Institutional Ethics Committee (IEC/AIIMS PAT/no: 92-2016 date: 22/8/2016). A total of 41 patients of apical POP who underwent abdominal mesh surgery during the study period of July 2016–June 2018, were evaluated for short term (6–24 months) surgical outcomes. Subjective evaluation of their vaginal symptoms, sexual wellbeing and overall quality of life was also carried out at follow up.

Sacrocolpopexy was performed in patients in 32 women presenting with vaginal vault prolapse. Abdominal sacrohysteropexy was performed in nine patients desirous of further childbearing or wishing to retain their uterus in ages less than 35 years. Objective assessment of POP was done using the pelvic organ prolapse quantification (POP-Q) scale at preoperative for baseline and every postoperative visit (6 weeks, 6, 12, 18 and 24 months). Subjective assessment of Quality of life (QOL) and postoperative subjective success was assessed using the International Consultation on Incontinence Questionnaire for Vaginal Symptoms (ICIQ-VS) at six months follow up visit.

After routine preoperative work-up and obtaining a written informed consent, patients underwent open abdominal surgical procedures of Sacro-hysteropexy and Sacro-colpopexy. Regional anesthesia and modified lithotomy position for surgery were used. Preoperative antibiotic prophylaxis was given to all patients. Non-absorbable synthetic, porous, monofilament polypropylene mesh was used for the fixation of the vault or cervix to sacrum.

In sacrocolpopexy, the bladder was dissected down anteriorly and the rectum was dissected down posteriorly and 5–6 cm area of the vaginal vault bared. The two short arms of Y shaped mesh was attached to vaginal vault by 2 rows of 3 sutures each. The hysteropexy mesh was attached only posteriorly at the cervical isthmic region over a 3–4 cm area with 3 rows of 2 sutures. Posterior point fixation of the long arm of Y- mesh was done to the anterior longitudinal ligament overlying the first or second sacral vertebra (S1 or S2) after opening the retroperitoneum between the right ureter and sigmoid colon. Routine closure of the retroperitoneum over the mesh was later carried out in all cases. Concomitant repair of pelvic floor defects, if any, was performed vaginally. Bilateral tubal ligation was performed in cases of sacrohysteropexy where no further childbearing was intended. The routine postoperative care was given and most patients were discharged on the seventh postoperative day after stitch removal. Patients were instructed to avoid strenuous activity, heavyweights lifting, straining on stools and to abstain

from sexual activity immediately postoperative period (6 weeks). Perioperative and postoperative complications were documented in the predesigned proforma for the study. First, follow-up of patients was done at six weeks and thereafter at 6<sup>th</sup>–12<sup>th</sup> months and at 12<sup>th</sup>–24<sup>th</sup> months post-procedure to assess surgical success and patient satisfaction. For the study, short term success of SCP was defined as Stage 0 or stage 1 apical prolapse on clinical examination (objective). Subjective assessment for vaginal symptoms, sexual wellbeing, and overall quality of life was done at six weeks visit. The questionnaire (ICIQ-VS questionnaire) was filled up at the 6 month follow up visit of all patients. We enquired about vaginal bulge symptoms, soreness, pain, dry sensation of vagina, coitus related problems like effect on sex life and relationship with the partner and any interference in everyday life due to vaginal symptoms. A set of 14 questions with answers scored from 0–10 was used. The questionnaire included questions on dragging pain, soreness, dryness, reduced sensation, too loose or lax, lump or vaginal bulge, need for digitation to pass stools, too tight, vaginal symptoms affecting life, sexual life interfered by vaginal symptoms and partner relationship affected by vaginal symptoms.

### Statistical analysis

All data collected was entered in Microsoft excel sheets and data cleaning done before statistical analysis. Numerical variables i.e., age, body mass index (BMI), parity and days of hospital stay were presented as mean  $\pm$  standard deviation. Parity as the median. Categorical variables e.g., factors associated with uterovaginal prolapse, its grade, duration of surgery, blood loss, complications of the operation, the success of the operation and patient satisfaction with the results of the procedure were presented as frequencies and percentages. Statistical analysis was performed by IBM SPSS statistical software v22. The range for study data are presented as Means and median. The difference in postoperative from preoperative POP-Q scoring and subjective outcomes has been calculated using Wilcoxon signed rank test.

## RESULTS

Out of 41 patients with pelvic organ prolapse included in the study, 32 underwent ASCP and nine - abdominal sacrohysteropexy. Preoperative all 41 patients had Stage III or IV POP-Q Stage. The mean age, mean BMI and median parity were comparable in both procedure groups. In the ASCP group, the mean age was 47 years, mean BMI: 23.5 kg/m<sup>2</sup> and median parity - 4. In the abdominal sacrohysteropexy group, mean age was 29.4 years, mean BMI: 21.4 kg/m<sup>2</sup> and median parity was 2 (Table 1).

Posterior colpoperineorrhaphy was the most commonly performed concomitant procedure while anterior colporrhaphy,

tubal ligation, Moschowitz repair were also done. In one patient, a concomitant abdominal hysterectomy was performed, followed by sacrocolpopexy to treat stage 4 pelvic organ prolapse (Table 2).

The mean operative time was 107 minutes including the time required to perform any concomitant procedures with average blood loss of 285 ml. Intraoperatively, severe pelvic adhesions were encountered in 14.6% (6/41) patient's apical prolapse patients, causing increased blood loss. A single intraoperative bladder injury was repaired simultaneously. Intraoperative hemorrhage (1000 ml) due to injury to presacral vessels occurred in one patient requiring two units of blood transfusion (Table 3).

In the postoperative period, the cause of concern was fever which occurred in 34% (14/41) of patients. Most febrile episodes subsided within the first 24 hours, however in four patients lasted for 72 hours. In spite of full aseptic precautions, 6/41 (14.7%) patients had abdominal wound infection leading to wound dehiscence which required secondary surgical repair and prolonged hospital stay. Postoperative ileus was noted in one patient who responded to conservative management. Most patients had nine days of hospital stay (three days before, and six days after the operation). Six patients (6/41, 14.5%) with wound complications had longer stay in hospital (Table 4).

During the six weeks follow-up (Table 5), five (12%) patients complained of constipation and were treated satisfactorily by a diet modification. Mild discomfort around the incision line was reported by 14.6% (6/41) patients. Vault infection was seen in two patients which responded to oral antibiotics. Two patients had recurrent urinary tract infection and 7.3% (3/41) patients

**Table 1. Patient characteristics**

Patient demographics	Sacrocolpopexy group	Sacrohysteropexy group
Mean age (years)	47 (42–66)	29.4 (26–35)
Mean BMI (kg/m <sup>2</sup> )	23.5 (21–27.8)	21.4 (19.4–27.2)
Median parity	3.5	2
BMI: Body mass index		

**Table 2. Concomitant procedures performed**

Posterior colpoperineorrhaphy	21 (51.2%)
Anterior colporrhaphy	8 (19.5%)
BSO	8 (19.5%)
Tubal ligation	7 (17%)
Incisional hernia repair	4 (9.75%)
Moschowitz repair	2 (4.8%)
Concomitant TAH, myomectomy, CPT repair	1 each (2.4%)
BSO: Bilateral salpingo-oophorectomy; TAH: Total abdominal hysterectomy; CPT: Current procedural terminology	

reported back pain. At the 6–12 months follow up visit, two complained of dyspareunia and another one had vaginitis. None of the patients developed mesh granuloma, mesh erosion or a

**Table 3. Intraoperative and postoperative complications**

Intra operative complication	
Severe adhesion encountered	9/41 (21.9%)
Cystostomy	1/41 (2.4%)
Bowel/rectal injuries	0
Haemorrhage (>1000 ml)	1/41 (2.4%)
Postoperative complication	
Fever (first day)	14 (34.14%)
Wound infection/dehiscence	6 (14.6 %)
Ileus	1 (2.4 %)
Abdominal wall haematoma	0
Sepsis	0
Urinary retention/UTI	0
UTI: Urinary tract infection	

**Table 4. Intra-operative measurements and hospital stay of study patients**

Mean blood loss (ml)	284.7 (150–1200 ml)
Mean operative time (min)	107 (50 min – 212 min)
Hospital stay (days)	9 (range: 6 – 30 days)

**Table 5. Follow up at 6<sup>th</sup> week, 6<sup>th</sup>–12<sup>th</sup> month and 13<sup>th</sup>–24<sup>th</sup> month**

Follow-up at 6 <sup>th</sup> week (n=41)	
Constipation	5 (12 %)
Incisional pain	6 (14.6 %)
Vaginal/vault infection	2 (4.8 %)
Recurrent UTI	2 (4.8%)
Buttock pain	3 (7.3%)
<b>De novo stress incontinence</b>	0
Follow up 6-12 months (n=41)	
Mesh granuloma	0
Dyspareunia	4 (9.7 %)
Mesh removal	0
Mesh erosion	0
POP-Q	Stage 0/1
Follow up at 12 <sup>th</sup> –24 <sup>th</sup> months (38)	
<b>De novo stress incontinence</b>	0
Mesh related complication	0
Dyspareunia	0
POP Q staging	Stage 0/1
UTI: Urinary tract infection; POP-Q: Pelvic Organ Prolapse Quantifications System; n: Number	

need of mesh removal. No mesh complications, *de novo* stress incontinence or vaginal bulge symptoms were reported. Patients reporting dyspareunia in the earlier visit were symptomless later. POP-Q staging was determined at each follow-up visit for all patients and the last recorded values were used for analysis. No patient had a prolapse in any compartment post-surgery. (Table 6). One patient who underwent sacrohysteropexy had a feeling of the vaginal bulge, and at examination a POP-Q Stage I anterior compartment prolapse was noted. Apical restoration in all the 41 patients was 100% (mean point C: -6.55 and mean point D: 8.8). It persisted throughout the follow-up of one year for 22 patients and for two years in 19 patients (Table 7).

In the hysteropexy group of patients (n=9), concomitant sterilization procedure was carried out in seven patients. One hysteropexy patient became pregnant and was delivered by caesarean section at 36 weeks with placenta previa. Her post-partum POP-Q scores remained the same as pre-pregnancy. One nulligravid woman underwent hysteropexy and was advised to undergo follow-up during future pregnancy. Significant subjective improvement was documented by patients in vaginal symptoms, sexual wellbeing and related quality of life, in the questionnaires (Table 8). Most operated patients - 31/35 (85.7%) experienced improvement in sexual function post-procedure. Four patients were not sexually active pre-procedure.

## DISCUSSION

Pelvic reconstructive procedures aim to correct POP by restoring normal vaginal supports, maintaining urinary and fecal continence, and preserving sexual function by maintaining vaginal capacity and position. ASCP using an open or laparoscopic route and vaginal SSF are the common reconstructive procedures carried out for vaginal vault prolapse. Surgical options for uterus preserving includes ventral hysteropexy (fixation of the uterus to the abdominal wall), transvaginal SSF and laparoscopic uterine suspension by suturing round ligaments to the rectus sheath or cervix to the pectineal ligament.

Age of the patient, presence of comorbidity, previous corrective surgical attempts and the level of post-operative physical and sexual activity desired are the factors that should decide the most appropriate procedure. Surgical expertise of the gynecologist for a particular procedure also influences the operative choices. Lane<sup>8</sup> in 1962 first described ASCP, where retroperitoneal synthetic, autologous or allograft prosthesis was placed between the vaginal vault and the sacral promontory.

Vaginal SSF, the other commonly performed procedure has a considerable success rate of 69%–91%.<sup>9</sup> When compared to sacrocolpopexy, SSF has a shorter operative time, lesser

**Table 6. Pre- and postoperative quantification of the prolapse**

Preoperative POP-Q measurement (cm)						
	Aa	Ba	C (n = 32)	D (n=9)	Ap	Bp
Mean	+1.9	+2.78	+4.4	-2	+0.72	+0.96
Median	+2	+4	+5	-3	+2	+2
Range	-2 to +3	-2 to +4.5	+2 to +6.5	-5 to +8	-3 to +3	-3 to +4
Post-operative POP-Q measurement (cm)						
	Aa	Ba	C (n = 32)	D (n=9)	Ap	Bp
Mean	-2.96	-2.88	-6.55	-8.8	-2.88	-2.88
Median	-3	-3	-7	-9	-3	-3
Range	-3 to -1	-3 to -2	-10 to -5	-10 to -8	-3 to -2	-3 to -2

POP-Q: Pelvic Organ Prolapse Quantifications System; n: Number

**Table 7. Improved postoperative status by POP-Q scores**

Diff. postoperative to preoperative						
	Aa	Ba	C	D	Ap	Bp
Mean*	-4.59*	-5.51*	-11.95*	-10.8*	-3.6*	-3.84*

\*Wilcoxon signed rank test; POP-Q: Pelvic Organ Prolapse Quantifications System

**Table 8. Subjective outcome by ICIQ vs questionnaire**

Preoperative ICIQ vs scores			
	VS Score (VS <sub>max</sub> =53)	SM Score (SM <sub>max</sub> =58)	QOL Score (QOL <sub>max</sub> =10)
Mean	26.64	38.63	8.47
Median	27	40	9
Range	12 to 35	19 to 58	5 to 10
Postoperative ICIQ vs scores			
	VS Score	SM Score	QOL Score
Mean	5.4	1.08	0.47
Median	6	0	0
Range	2 to 12	0 to 2	0 to 5
Change in ICIQ vs scores			
	VS Score	SM Score	QOL Score
Difference of mean	-21.2*	-37.4*	-7.9*
Median	-21	-40	-8
Range	-6 to -33	-22 to-57	-5 to-10

ICIQ: Incontinence questionnaire; VS: Vaginal Symptoms; QOL: Quality of Life Questionnaire

complication, quicker recovery and less expensive. But SSF is not appropriate in a sexually active woman and in those having a shortened vagina. In a Cochrane review, ASCP was found to be associated with a lower rate of recurrent vault prolapse compared to the vaginal SSF.<sup>5</sup> The reported success rate with ASCP is 78%–100%.<sup>10</sup> The present study of 41 patients has also shown a 100% subjective and objective success rate over a the 24 months follow up period.

Newer surgical approaches like pectopexy where the vaginal vault is attached bilaterally to the iliopectineal ligaments, is advantaged by improved defecation scores over the sacrocolpopexy.<sup>11</sup>

Although laparoscopic route of sacrocolpopexy is advantaged by less operative blood loss, shorter hospital-stay and a quicker return to daily activity, the operative time is longer than open sacral colpopexy.<sup>12</sup> Some studies have however reported similar operating times.<sup>13</sup> As the overall complication rate is not significantly different between open or laparoscopic SCP, the evidence is inconclusive for the choice of the most appropriate procedure.<sup>14</sup>

No life-threatening events occurred in any of the study participants in this study and the major intraoperative complications in this study were operative hemorrhage (1/41) due to presacral vessel injury and bladder injury during dissection from vault (1/41). Immediate severe postoperative complication was postoperative febrile episodes in 34% of patients. 14.6% of patients had surgical site infection (SSI) of abdominal wound dehiscence requiring secondary surgical closure of abdominal wound. Postoperative ileus was noted in a single (2.4%) patient who responded to conservative treatment.

At the six weeks follow up, constipation (11.7%) and vaginitis (2.4%) were reported by patients, which responded to medications. *De novo* stress urinary incontinence which has been reported to occur postoperatively in many studies was not encountered in our group of patients. Dyspareunia (9.7%) was the only complication at 6<sup>th</sup>–12<sup>th</sup> months follow up of patients in cases



where pelvic floor repair was done pointing to perineorrhaphy as the cause rather than mesh placement.

Vaginal bleeding, discharge and pain after SCP can be due to mesh erosion and patients should be counselled to report immediately at discharge from hospital and follow-up visits. Mesh exposure is a complication with both open and laparoscopic SCP which has been reported between 2% and 10% out of which 10% may require mesh removal.<sup>2</sup> In our cohort of patients, there were no cases of mesh related complications for the entire period of follow up. However, long term follow-up is warranted as there is an ongoing risk of mesh related events. A newer method of mesh surgery follow-up of 32 patients by transperineal 4D ultrasound has been reported, where no mesh erosions were reported.<sup>15</sup> ASCP effectiveness should always be balanced with long-term risks of mesh or suture erosion.

In the present study, the sacrohysteropexy cases experienced a 100% objective and subjective success rates. The mesh was fixed only to the posterior cervical-uterine junction for the caudal attachment and has been previously reported to be safe.<sup>16</sup> For those who have a recurrence of apical prolapse, sacrospinous hysteropexy can be performed as it has been found to be non-inferior to vaginal hysterectomy with uterosacral suspension.<sup>17</sup> However, Maher et al.'s<sup>14</sup> Cochrane review has not concluded clearly in favor of either uterine preserving surgery or vaginal hysterectomy for uterine prolapse.

Nair et al.<sup>18</sup> in their review comprising 660 women from their included list of 16 studies on laparoscopic hysteropexy, reported only six pregnancies and five deliveries following the procedure. None of these patients had a recurrence of the prolapse after delivery.<sup>18</sup> In the present study of 9/41 sacrohysteropexy, only two desired childbearing. One conceived spontaneously and delivered a healthy term baby by cesarean section. The mesh was not discernible retroperitoneally during cesarean section and the uterus was well supported post-delivery even after 6 months of follow up.

Transvaginal procedures using vaginal mesh had been introduced for hysteropexy but most are complex procedures, require specialized training and lacking much evidence in favor. They avoid the abdominal incision associated complications and are sufficient to support the vaginal apex.<sup>19</sup> However, currently, they lack Food and Drug Administration approval.

In the present study, no vaginal bulge symptoms were reported by any patient following the procedure and a marked improvement in subjective scores was reported by all participants. Women who were sexually active before surgery remained so after surgery with improved sexual scores. There was an overall improvement in the QOL of all participants in this study.

As this study is of a single centre, the number of cases are limited, belong to a particular area and only a two year follow up has been done till now. As shown by few long-term studies, mesh related complications and recurrence of prolapse are best assessed on extended follow-up. The study participants are on an annual follow up plan and will be evaluated for surgical success and subjective improvement after abdominal mesh surgery in coming years over a long-term basis.

## CONCLUSION

ASCP and sacro-hysteropexy are relatively easy to perform procedures with acceptable and good anatomical success rates. They provide optimum apical support as well as a good functional outcome and high cure rates for patients of apical vaginal prolapse. There is a significant overall improvement in vaginal symptoms, sexual function, and quality of life of women with POP undergoing these procedures and this advantage should be considered when offering these procedures.

## Contributions

Surgical and Medical Practices: M.A., Mu.A., S.K., A.P., Concept: M.A., Design: M.A., A.S., Data Collection or Processing: M.A., A.S., S.G., Mu.A., S.K., A.P., Analysis or Interpretation: M.A., A.S., S.G., Literature Search: M.A., A.S., S.G., Mu.A., S.K., A.P., Writing: M.A.

## Ethics

**Ethics Committee Approval:** Institutional Ethics Committee AIIMS Patna (IEC/AIIMS PAT/ no: 92-2016 date: 22/8/2016).

**Informed Consent:** A written informed consent form was obtained from the patients.

**Peer-review:** Externally peer-reviewed.

## DISCLOSURES

**Conflict of Interest:** No conflict of interest was declared by the authors.

**Financial Disclosure:** The authors declared that this study received no financial support.

## REFERENCES

1. Walter JE; UROGYNAECOLOGY COMMITTEE. Transvaginal mesh procedures for pelvic organ prolapse. *J Obstet Gynaecol Can* 2011; 33: 168-74.
2. Cundiff GW, Varner E, Visco AG, et al. Risk factors for mesh/suture erosion following sacral colpopexy. *Am J Obstet Gynecol* 2008; 199: 688.e1-5.
3. Haylen BT, Maher CF, Barber MD, et al. An International Urogynecological Association (IUGA) / International Continence Society (ICS) Joint Report on the Terminology for Female Pelvic Organ Prolapse (POP). *Neurourol Urodyn* 2016; 35: 137-68.

4. Uzoma A, Farag KA. Vaginal vault prolapse. *Obstet Gynecol Int* 2009; 2009: 275621.
5. Maher C, Feiner B, Baessler K, Adams EJ, Hagen S, Glazener CM. Surgical management of pelvic organ prolapse in women. *Cochrane Database Syst Rev*. 2010; (4): CD004014.
6. Walters MD, Ridgeway BM. Surgical treatment of vaginal apex prolapse. *Obstet Gynecol* 2013; 121: 354-74.
7. Tyagi V, Hawthorn R, Guerrero K. Sacrocolpopexy (SCP) - A cohort study looking at short, medium and long term outcome. *Med Surg Urol* 2013; 2: 1-4.
8. Lane FE. Repair of posthysterectomy vaginal-vault prolapse. *Obstet Gynecol* 1962; 20: 72-7.
9. Post-Hysterectomy Vaginal Vault Prolapse. Green-top Guideline No. 46. RCOG/BSUG Joint Guideline. Royal College of Obstetricians and Gynaecologists; Jul, 2015.
10. Nygaard I, Brubaker L, Zyczynski HM, et al. Long-term outcomes following abdominal sacrocolpopexy for pelvic organ prolapse. *JAMA* 2013; 309: 2016-24.
11. Noé KG, Schiermeier S, Alkatout I, Anapolski M. Laparoscopic pectopexy: a prospective, randomized, comparative clinical trial of standard laparoscopic sacral colpocervicopexy with the new laparoscopic pectopexy-postoperative results and intermediate-term follow-up in a pilot study. *J Endourol* 2015; 29: 210-5.
12. ACOG Committee on Practice Bulletins--Gynecology. ACOG Practice Bulletin No. 85: Pelvic organ prolapse. *Obstet Gynecol* 2007; 110: 717-29.
13. Coolen AL, van Oudheusden AM, van Eijndhoven HW, van der Heijden TP, Stokmans RA, Mol BW, Bongers MY. A Comparison of Complications between Open Abdominal Sacrocolpopexy and Laparoscopic Sacrocolpopexy for the Treatment of Vault Prolapse. *Obstet Gynecol Int* 2013; 2013: 528636.
14. Maher C, Feiner B, Baessler K, Christmann-Schmid C, Haya N, Brown J. Surgery for women with apical vaginal prolapse. *Cochrane Database Syst Rev* 2016; 10: CD012376.
15. Eisenberg VH, Steinberg M, Weiner Z, Schiff E, Lowenstein L. Long-term follow-up of sacrocolpopexy mesh implants at two time intervals at least 1 year apart using 4D transperineal ultrasound. *Ultrasound Obstet Gynecol* 2017;49:398-403.
16. Khan A, Jaleel R, Nasrullah FD. Sacrohysteropexy performed as uterus conserving surgery for pelvic organ prolapse: Review of case files. *Pak J Med Sci* 2016; 32: 1174-8.
17. Detollenaere RJ, den Boon J, Stekelenburg J, et al. Sacrospinous hysteropexy versus vaginal hysterectomy with suspension of the uterosacral ligaments in women with uterine prolapse stage 2 or higher: multicentre randomised non-inferiority trial. *BMJ* 2015; 351: h3717.
18. Nair R, Nikolopoulos KI, Claydon LS. Clinical outcomes in women undergoing laparoscopic hysteropexy: A systematic review. *Eur J Obstet Gynecol Reprod Biol* 2017; 208: 71-80.
19. Kong MK, Bai SW. Surgical treatments for vaginal apical prolapse. *Obstet Gynecol Sci* 2016; 59: 253-60.



# Kees classification of obstetric and other urine fistulas as based on quantitative and qualitative pelvis tissue loss and on the continence mechanism

KEES WAALDIJK

National Obstetric Fistula Center Babbar Ruga, Katsina, Nigeria

## ABSTRACT

**Objective:** A classification of the obstetric and other urine fistulas is presented based on pelvis tissue loss and involvement of the anatomic continence mechanism:

**Materials and Methods:** Kees I fistulas: not involving the continence mechanism;

Kees IIAa fistulas: involving the continence mechanism without (sub)total urethra involvement and without a circumferential defect;

Kees IIAb fistulas: involving the continence mechanism without (sub)total urethra involvement and with a circumferential defect;

Kees IIBa fistulas: involving the continence mechanism with (sub)total urethra involvement and without a circumferential defect;

Kees IIBb fistulas: involving the continence mechanism with (sub)total urethra involvement and with a circumferential defect and miscellaneous;

Kees III fistulas: like ureter fistulas;

**Results:** The characteristics of each class are described and why they differ from each other by qualitative and quantitative pelvis tissue loss. There is a fluid transition from Kees I into Kees IIAa and from Kees IIAa into Kees IIBa and from Kees IIAa into Kees IIAb and from Kees IIAb into Kees IIBb fistulas. Each fistula class needs to undergo a specific operation: from incision to dissection to repair of pelvis structures, in addition to fistula closure. This is to reconstruct the functional pelvis anatomy.

**Conclusion:** With this classification it is possible to plan and execute the fistula repair according to the principles of reconstructive surgery and to compare the operation techniques and results in a scientific way. However, these are only guidelines as each fistula constitutes its own unique entity and needs its own customized approach.

**Keywords:** Obstetric fistula; classification; pelvis tissue loss; endopelvic diaphragm; operation principles

## INTRODUCTION

The variety of fistula caused by obstetric trauma is immense. It ranges from a minute urine fistula with minimal tissue loss, to a cloaca in an empty pelvis with extensive intravaginal lesions and

(sub)total loss of the intrapelvic soft tissues, neurologic lesions such as foot drop, extravaginal lesions such as bedsores and loss of labia, urine-induced dermatitis, stones, and systemic lesions such as severe anemia and even cachexia.

**Address for Correspondence:** Kees Waaldijk, National Obstetric Fistula Center Babbar Ruga, Katsina, Nigeria

**E-mail:** Kees.waaldijk@yahoo.com **ORCID:** orcid.org/0000-0002-4545-6832

**Received:** 06 March 2021 **Accepted:** 16 April 2021

©Copyright 2021 by the International Society for Pelviperineology / Pelviperineology published by Galenos Publishing House.

The lesions are caused by intravaginal pressure necrosis, intrapelvic compression of deep structures, immobilization, continuous urine leakage and blood loss. An enormous amount of metabolic energy is consumed during prolonged obstructed labor which may last for days. In addition, fistulas may also develop consequent to practices by the birth attendant such as craniotomy, vacuum delivery, forceps delivery and cesarean section.

In order to make a plan of action to fistula correction, to develop surgical principles, to evaluate different operation techniques and to analyze the results in an objective way, a classification is needed which makes sense; the classification should be objective with clear definitions and parameters and not too complicated.

Based on a retrospective analysis in 775 consecutive patients with fistulas, such a scientific classification was developed and has been used and refined by the author in some 29,000 personal fistula repairs, and in related operations in roughly 25,000 patients during a 35-year period of management of obstetric trauma. The practice involved mainly Nigeria, but also Burkina Faso, Nepal, Niger, Kenya and Tanzania from 1984 up till today.<sup>1-7</sup>

## MATERIALS AND METHODS

### Classification

The rationale of developing this fistula classification method was that since ensuring urine continence after successful closure is the major challenge, any classification must include the urine continence mechanisms as a major decisive inherent component. The anatomic urine continence mechanism in the female consists of the presence of the whole urethra of 3-3.5 cm +1-1.5 cm distal bladder neck; so, in total over 4-5 cm needs to exist, with the external urethra opening as reference point (Figures 1-4). The classification is presented in Table 1. Figure 4 is a simplified graphic illustration on a balloon. The classification is based on the progressive quantitative and qualitative amount of pelvis tissue loss and on the progressive involvement of the urine continence mechanism.

In Kees I fistulas there is tissue loss of the bladder, pubocervical musculofascia (PCMF) which is a part of the endopelvic diaphragm (EPD) and anterior vagina wall (AVW) and/or the cervix and/or the uterus. The continence/closing mechanism remains intact. The anchoring of the anterior cervix within the endopelvic diaphragm may be defective. There may be a major tissue loss, and sometimes a trauma to the sacrospinous ligament, (ischio) coccygeus muscles and piriformis muscles. Frequently it is associated with cesarean section (CS) or CS-subtotal hysterectomy or CS-total hysterectomy.

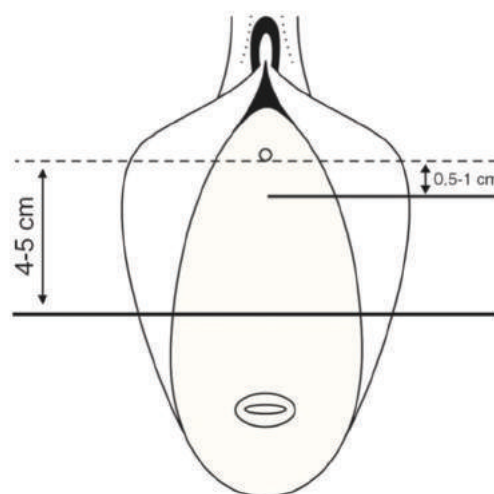

Figure 1. Urine continence mechanism: frontal

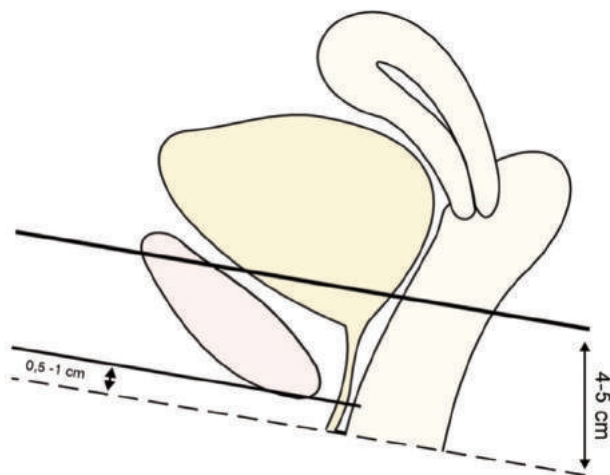

Figure 2. Urine continence mechanism: sagittal



Figure 3. Anatomic urine continence mechanism

**Table 1. Classification of fistulas according to anatomic location or physiologic deficit**

Type of fistula	Sub-type	Sub-sub-type	Description
I			Without involvement of the continence (closing) mechanism
II	A		Without total or subtotal involvement of the urethra
		Aa	Without circumferential defect
		Ab	With circumferential defect
	B		With total or subtotal involvement of the urethra
		Ba	Without circumferential defect
Bb	With circumferential defect		
III			Miscellaneous, e.g. ureter fistulas and other exceptional fistulas

In Kees IIAa fistulas there is tissue loss of the bladder, urethrovesical (UV)-junction/trigonal ring, detrusor loops, proximal and possibly mid urethra, PCMF/EPD and AVW (with the cervix and/or the uterus). In addition, minor to moderate involvement of the continence/closing mechanism exists. There may be a slight trauma to the ATF, arcus tendineus of the levator ani muscle (ATLAM) and the levator ani musculature. There may be a transverse or a quartercircular defect within the PCMF/EPD. This may lead to indirect disruption or weakening of its connection to the paraurethral pubis bones and paraurethra ATF. The ATF and the ATLAM are usually intact. The defect within the PCMF/EPD is larger than the fistula. The fistula may be found within this defect.

In Kees IIAb fistulas there is a circumferential tissue loss of the bladder neck, UV-junction and trigonal ring, detrusor loops, proximal or mid urethra and tissue loss of posterior pubourethral ligaments, PCMF/EPD, AVW (and cervix and/or uterus), ATF, ATLAM, pubococcygeus muscles and iliococcygeus muscles. In addition, a trauma to the obturator internus muscles, obturator membrane and coccygeus muscles may occur, with eventual loss of the pubis bone periost and the pubis symphysis cartilage, with moderate to major involvement of the continence/closing mechanism. There is no functional tissue connection whatsoever between the traumatized urethra or what is left of it, and the traumatized bladder neck. The urethra has usually been retracted distally, and the bladder proximally in opposite directions whilst the paravesical space is opened. The stabilizing support of the PCMF/EPD needed for the physiologic urethra continence/closing function, is usually lost and there is

no connection between what is left of the traumatized PCMF/EPD and the paraurethral pubis bones. The anterior part of the PCMF/EPD, together with the paraurethral and distal part of the ATF are completely lost.

In Kees IIBa fistulas there is major tissue loss of the urethra and of the UV-junction/trigonal ring, detrusor loops, bladder, PCMF/EPD and AVW (and cervix and/or uterus) with major involvement of the continence/closing mechanism. Though there is tissue loss of the anterior part of PCMF/EPD, the ATF, ATLAM and levator ani musculature are intact. Due to the natural tissue forces inside the human body, the endopelvic diaphragm with adherent traumatized posterior bladder neck retracts towards the cervix/sacrum. There is also a dislocation and/or loss of the posterior UV-junction. The stabilizing support of the PCMF/EPD needed for the physiologic urethra continence/closing function has been lost. This is because of an anterior defect in the PCMF/EPD whilst its anterior connection to the immediate paraurethral pubis bones has been disrupted.

In Kees IIBb fistulas there is total or subtotal circumferential tissue loss of the urethra, UV-junction/trigonal ring, bladder neck, detrusor loops and tissue loss of the posterior pubourethral ligaments, PCMF/EPD, AVW (and cervix and/or uterus), ATF, ATLAM, pubococcygeus/iliococcygeus muscles. In addition, there may also be a trauma to the obturator internus muscles, obturator membrane and coccygeus muscles with eventual loss of pubis bone periost and pubis symphysis cartilage. There is an extensive involvement of the continence/closing mechanism whilst the paravesical space is opened. There is no functional tissue connection whatsoever between what is left of the severely traumatized urethra if anything is left at all of it, and the traumatized bladder neck, whilst the bladder has retracted proximally. The retraction is limited anteriorly by the loose fixation of the anterior bladder onto the posterior symphysis and anterior abdominal wall. The anterior part of the PCMF/EPD has been lost completely together, with bilateral loss of the paraurethral and distal part of the ATF. In addition, its bilateral semicircular anterior connection onto the paraurethral pubis bones and bilateral ATF is directly disrupted. In extensive trauma there may even be a complete bilateral loss of the ATF from the paraurethra and up to the ischium spine. The cephalad part of the pubococcygeus muscle has been lost with total or subtotal loss of the paraurethral ATLAM. In extensive trauma, the cephalad part of the iliococcygeus muscle is lost as well, with complete ATLAM loss from the paraurethra up to the ischium spine. this is associated with a very extensive tissue loss, making the surgical management very complicated in these fistulas. Frequently an empty pelvis is found with bare pubis bones. In these cases, the fistula may be inoperable.

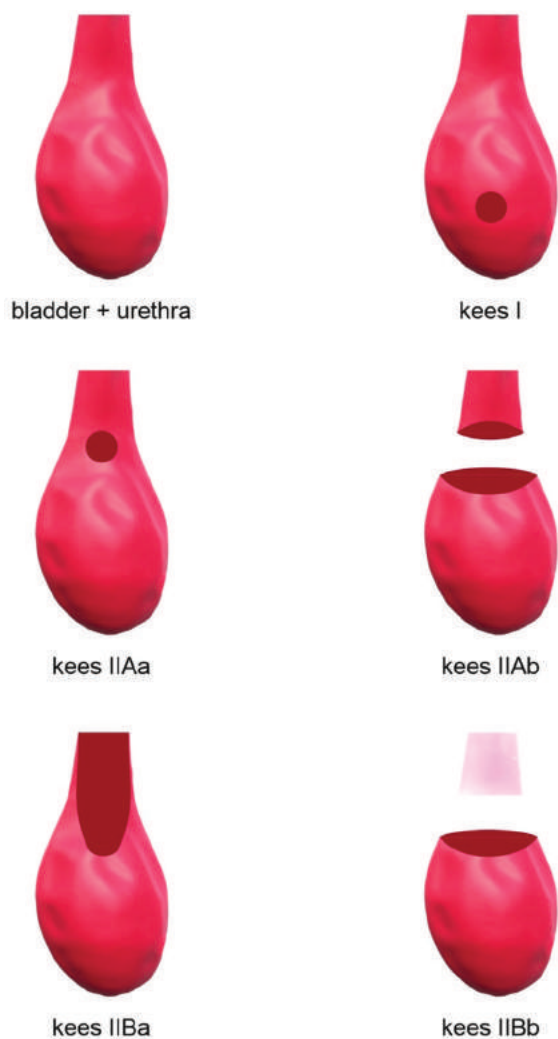

Figure 4. Kees urine fistula classification

The transition from Kees I into Kees II fistulas is at 4-5 cm and the transition from Kees IIA into Kees IIB fistulas is at 0.5-1 cm from the external urethra opening.

The Kees III fistula is an independent class, including a ureter fistula, a fistula between the bladder and bowel, and fistula between the bladder and skin.

**Mechanism of action in circumferential fistulas**

Due to the total disruption of the bilateral anterior PCMF/EPD from the pelvis wall, and the circumferential disruption of the bladder neck from the urethra, the PCMF/EPD and bladder neck retract towards the cervix/sacrum. This retraction is restricted by the loose fixation of the anterior bladder neck to the posterior symphysis and anterior abdominal wall by connective tissue. Since the bilateral semicircular anterior fixation of the PCMF/EPD to the ATF and paraurethral pubis bone is also disrupted, the loose PCMF/EPD with adherent posterior bladder wall retracts towards the anterior bladder wall. This is due to the natural tissue

forces. The bladder then loses its saucer shape configuration when empty. The PCMF/EPD with adherent posterior bladder wall move anteriorly, towards the symphysis, and cephalad towards the superior pubis bone rami. They may then reconnect with the obturator internus fascia or superior pubis bone rami, at a more cephalad level resulting in deep bilateral anterior vagina sulci. This may extend up to the superior pubis bone rami. This mechanism explains why the fistula retracts and becomes less accessible behind the pubis symphysis. In some instances the anterior bladder wall retracts cephalad above the superior brim of the symphysis. It is the cephalad part of the levator ani muscle, together with its origin ATLAM, which are lost whilst the caudad part with its insertion into the levator plate and coccyx is still intact. If there is a major loss of the levator ani musculature, the result is an empty pelvis with bare pubis bones. This consequence is always combined with total or subtotal loss of the ATF and ATLAM from the paraurethra up to the ischium spine.

**Operative principles**

Since the fistula is a part of an obstetric trauma, the functional pelvis anatomy has to be reconstructed, while the fistula is closed during the procedure. Restoring the anatomy will ensure resuming the normal physiology. Special attention should be paid not to occlude the ureters. The surgical procedures may vary according to the present lesions and characteristics, but always include incision, restoring the bladder and urethra closure, and PCMF/EPD reconstruction and anterior vagina wall adaptation..

In Kees I fistulas, the incision extends around the fistula’s edge with eventual bilateral transverse extension. Alternatively, a “physiologic” incision should be carried out at the anterior cervix in vesicocervical and vesicouterine fistulas. Sharp dissection and transverse, oblique or longitudinal bladder closure as needed by a single layer of inverting absorbable sutures. The surgeon then needs to check the connection of PCMF/EPD onto the anterior cervix and correct it if needed. Then checks on the closure and continence. Finally, insertion and fixation of catheter should be followed by AVW/cervix adaptation.

In Kees IIAa fistulas, physiologic incision is carried out within the vagina rugae through the fistula and then around the fistula edge. Then a transverse repair of the defect within the PCMF/EPD, with bladder or urethra closure using a single layer. During the procedure the surgeon should check on any loose connection of PCMF/EPD to bilateral anterior pelvis wall and correct this if necessary. and check the closure and continence. Then the surgeon should insert and fixate the catheter and make sure there is a transverse AVW adaptation rarely, a longitudinal closure is indicated.

In Kees IIAb fistulas, the first incision should start around the fistula's edge. The second physiologic incision should be carried out through the fistula in between the anterior bladder neck and the posterior symphysis, or the other way around, for circumferential dissection and mobilization of the bladder neck, distal advancement of the bladder neck and circumferential end-to-end anastomosis as vesicourethrostomy. Then a quartercircular fixation of the PCMF/EPD to the paraurethral pubis bones and bilateral ATF should be made. At this stage the surgeon should check on the closure and continence, insert and fixate the catheter and then AVW adaptation. If a complete circumferential end-to-end anastomosis is not possible or too complicated, a 4/5-, 3/4- or 2/3- circumferential dissection is performed followed by 4/5-, 3/4- or 2/3- "end-to-end" vesicourethrostomy, where the symphysis "closes" the gap between the anterior bladder neck and the anterior urethra.

In Kees IIBa fistulas, wide H incision should be carried out bilaterally, from the urethral fistula through the sulci with the horizontal part at the proximal fistula edge. This should be followed by sharp dissection of the AVW, mobilization of the retracted paraurethral tissue, and then by a longitudinal inverted T urethral reconstruction with repositioning of dislocated posterior UV-junction. The next stage is re-fixation of the PCMF/EPD onto the paraurethral pubic bones. The surgeon then should check on closure and continence, insert and fixate the catheter and reconstruct the AVW using the already dissected AVW as an advancement flap.

In Kees IIBb fistulas, the author prefers to use a two-stage procedure. Initially, First stage: Start with a wide H incision bilaterally from the "urethra" through the sulci. The horizontal part should be at the proximal fistula edge. Then, a second dissecting incision should be carried out, between the anterior bladder neck and the posterior symphysis, for circumferential dissection/mobilization, distal advancement of mobilized bladder (neck) and tapering fixation into the original "external urethra opening". Then a semicircular anterobilateral fixation of PCMF/EPD onto paraurethral pubis bones and bilateral "ATF" should be performed and then AVW adaptation. The surgeon should then check the continence, insert and fixate the catheter. If a post-repair incontinence develops, a second stage urethral reconstruction should be performed using bladder tissue as described under repair of Kees IIBa.

A one-stage operation using an anterior, lateral or posterior bladder flap for urethra reconstruction is possible, but the results are not optimal.

The Kees III fistulas need a customized approach, e.g. abdominal or vaginal ureter re-implantation

## RESULTS

### Outcome of fistula surgery

The series include 1,716 consecutively operated patients, who had a fistula for less than three months and were not operated before. A final follow up examination was performed 5-6 months postoperatively. The results are shown in table II. All patients were operated by one surgeon, the author, under the same pre, intra- and post-operative conditions. The same team and the same instructions were used. The table shows that the more the continence mechanism is affected, the more post-repair incontinence might develop. Kees IIBb fistulas which were the most complicated to repair, resulted with the worst outcome of healing and continence.

**Table 2. Outcome of fistula surgery by Kees type in 1,716 consecutive patients**

Type/subtype	Number of patients	Healed after 1 <sup>st</sup> surgery n, (%)	Final healing - n, (%)	Still incontinent n, (%)
I	243	238 (97.9)	242 (99.6)	1 (0.4)
IIBa	888	868 (97.4)	888 (100)	11 (1.2)
IIBb	366	333 (91.0)	353 (96.4)	30 (8.5)
IIBa	87	80 (96.4)	86 (98.9)	14 (16.3)
IIBb	132	114 (86.4)	121 (91.7)	59 (48.8)

## DISCUSSION

The variety of the complex obstetric trauma is immense, so that it is impossible to develop an ideal classification of the obstetric fistula. In fact, each fistula constitutes of its own specific entity. Therefore, within each fistula type, many subtypes exist. Not only the fistula has to be classified, but all the lesions and defects have to be objectively documented in writing to be completely transparent. Vaginal strictures, scarring, stenosis, fistula size and previous repair attempts are not a part of the classification, but they may complicate the operation and decrease healing and continence success.

The characteristic of the circumferential fistulas is the complete disruption of what is left of the traumatized urethra, from the traumatized bladder neck, with opening of the paravesical space. The classification should be performed during examination under anesthesia at the beginning of the reconstructive surgery, with the patient totally relaxed and in the exaggerated lithotomy position after a thorough examination of all the obstetric trauma lesions that exist. Only then, a plan of action should be made.

## CONCLUSION

With the Kees' classification it is possible to plan and execute a fistula repair according to the principles of reconstructive surgery, and to compare the operation techniques and results in a scientific way. However, since the variety of fistula variations is immense and there are no sharp demarcations transition between the different types is possible. Therefore this classification should be used as a guideline. Each fistula needs its own customized approach, and that is exactly what makes obstetric fistula surgery so intriguing!

### Ethics

**Ethics Committee Approval:** For this study type an ethics committee is not necessary.

**Informed Consent:** Not necessary.

**Peer-review:** Externally peer-reviewed.

## DISCLOSURES

**Financial Disclosure:** The author declared that this study received no financial support.

## REFERENCES

1. Hafferl A. Lehrbuch der topographischen Anatomie. Springer Verlag; 1957.
2. Marani E, Koch WFRM. The pelvis: structure, gender and society. Springer Verlag; 2014.
3. Petros PE. The female pelvis floor, Function Dysfunction and Management according to the Integral Theory. Springer Heidelberg; 2010.
4. Waaldijk K: The (surgical) management of bladder fistula in 775 women in Northern Nigeria. PhD thesis Univ. of Utrecht; 1989.
5. Waaldijk K: Obstetric trauma surgery; art and science: 004 basics. Printmarkt; 2008.
6. Waaldijk K: Obstetric trauma surgery; art and science: 013 corpus intrapelvinum with endopelvic diaphragm. Printmarkt; 018.
7. Waaldijk K: Obstetric trauma surgery; art and science: 020 Kees urine fistula classification. Printmarkt; 2020.





# Long-term effects of a placebo-controlled trial of enoxaparin for treatment of severe provoked vulvodynia

ELAD OFIR<sup>1</sup>, EILAM PALZUR<sup>2</sup>, JACOB BORNSTEIN<sup>1,2,3</sup>

<sup>1</sup>Azrieli Faculty of Medicine, Bar Ilan University, Safed, Israel

<sup>2</sup>Research Institute, Galilee Medical Center, Nahariya, Israel

<sup>3</sup>Department of Obstetrics and Gynecology, Galilee Medical Center, Nahariya, Israel

## ABSTRACT

**Objective:** Provoked vulvodynia (PV) is the main cause of dyspareunia, affecting millions of women worldwide. Its cause is yet unknown, and treatment is empirical in most cases. Our purpose was to assess the long-term beneficial effects of enoxaparin on PV.

**Materials and Methods:** Women who previously participated in a three-month trial comparing enoxaparin to placebo for the treatment of severe PV were evaluated regarding their current pain levels using Numeric Rating Scale with various activities, whether they sought additional treatment for their condition and their satisfaction with their treatment. For pain levels, we compared time-time points within groups using a paired-sample t-test or Wilcoxon signed rank test, and we compared groups at any given time point using an independent-samples t-test or a Wilcoxon rank-sum test.

**Results:** Thirty-one of the 39 original participants completed the follow-up survey; 17 had been treated with enoxaparin, and 14 had received saline. Compared to their pain at the end of the prior trial, at the time of the present study, those treated with enoxaparin experienced greater decreases in pain during intercourse (34% decrease,  $p=0.012$ ) than those who received placebo (22.5% decrease,  $p=0.064$ ); this was also true for other activities.

**Conclusion:** Enoxaparin exhibited continuing benefits three years after daily treatment for 90 days for severe PV and may have an implication for women suffering from PV.

**Keywords:** Enoxaparin; provoked vulvodynia; chronic pain

## INTRODUCTION

Provoked vulvodynia affects millions of women worldwide. It is estimated that 3%–16% of women will suffer from chronic vulvar pain that will last at least 3 months.<sup>1</sup>

Patients complain that intercourse, as well as everyday activities such as sitting, tampon insertion or wearing tight clothing, become unbearable. Forty-two percent of afflicted women

report significant suffering and feeling a loss of control over their lives, and they may develop secondary depression.<sup>1</sup>

Diagnosis relies on history and a physical exam and excluding conditions leading to vulvar pain. Symptoms include pain during vaginal penetration and vestibular sensitivity following localized pressure lasting at least 3 months. Eliciting pain or increased sensitivity by a cotton swab in the vestibule confirms the diagnosis.

**Address for Correspondence:** Jacob Bornstein, Department of Obstetrics and Gynecology, Galilee Medical Center, Nahariya, Israel

**E-mail:** mdjacob@gmail.com **ORCID:** orcid.org/0000-0003-1932-5270

**Received:** 11 May 2021 **Accepted:** 11 May 2021

There are several hypotheses regarding the physiological causes of provoked vulvodynia, including genetic polymorphisms that cause an increase in pro-inflammatory factors along with a concomitant decrease in anti-inflammatory factors;<sup>2,3</sup> decreased immune response to candida vulvovaginitis;<sup>4</sup> inflammation of the minor vestibular glands;<sup>5</sup> dysfunction of pelvic floor musculature;<sup>6</sup> hormonal causes;<sup>7</sup> bladder pain syndrome/interstitial cystitis;<sup>8</sup> and allergens.<sup>9</sup> Recently, the predominant theory for provoked vulvodynia is that neuro-proliferation within the epithelial and dermis layers leads to an increase in pain sensitivity.<sup>10,11</sup>

Most treatment options are empirically based and not always successful. They include pain management, pelvic floor physical therapy and psycho-social therapy, including cognitive-behavioral therapy, as well as vestibulectomy when other measures fail.

Proliferation and degranulation of mast cells results in increased heparanase levels,<sup>10,11</sup> causing the degradation of the extracellular matrix residing proteoglycan, heparan sulfate. This degradation leads to the release of heparin binding growth factors, enzymes and plasma proteins, thus leading to weakening of the extracellular matrix. Support for the heparanase theory comes from a previously reported study from our center (previous study) that prospectively compared patients randomly treated with subcutaneous enoxaparin,<sup>12</sup> a heparanase inhibitor, or with saline as placebo. In that previous study, the enoxaparin-treated women showed a greater reduction in vestibular sensitivity at the end of treatment and three months later (29.6% compared with 11.2%,  $p=0.004$ ). Seventy-five percent (15 of 20) of them reported more than 20% pain reduction compared with 27.8% (five of 18) in the placebo group ( $p=0.004$ ). Seven enoxaparin-treated women compared with three in the placebo group had almost painless intercourse at the end of the previous study. In women who had improvement of sensitivity, a repeat biopsy at the site parallel to the original biopsy site, showed a histologically documented reduction in the number of intraepithelial-free nerve fibers in the enoxaparin treated group.

The goal of the present study was to assess the long-term effects of enoxaparin among patients suffering from provoked vulvodynia who previously participated in a 3-month trial comparing enoxaparin to placebo.

## MATERIAL AND METHODS

### Ethical approval

The present study was approved by the Institutional Review Board (IRB) of the Galilee Medical Center of the Israeli Health

Ministry, on June 2<sup>nd</sup>, 2013. Authorization number: 0039-13-NHR. This approval is different from the one given for the previous study. Written informed consent was obtained from all subjects.

### Previous study

The present study is a follow-up to a prospective, randomized, double-blind previous study of enoxaparin treatment for provoked vulvodynia.<sup>12</sup> Clinical trial registration of the previous study: [clinicaltrials.gov](https://clinicaltrials.gov), NCT00874484.

The previous study ended 3 years before the onset of the present study.<sup>12</sup> Safety control was done using anti-factor Xa blood levels. Since enoxaparin mechanism of action involves inactivation of factor Xa without significant inhibition of thrombin, measurement of anti Xa activity in the previous study ascertained the prior administration of enoxaparin, and ensured that it does not exceed the therapeutic range. The previous study recruited 40 women, of which 39 were included. They were all diagnosed with provoked vulvodynia according to Friedrich's first two criteria for vulvar vestibular syndrome: severe pain in the vulvar vestibule on touch or attempted vaginal entry and tenderness to pressure localized within the vulvar vestibule. The level of provoked vulvodynia was severe, according to Marinoff's definition.<sup>13</sup> Women were considered for enrollment to the previous study if they were aged 18–50 years, desired vaginal intercourse, had an available sexual partner, met Friedrich's first two criteria for vulvar vestibular syndrome i.e, severe pain in the vulvar vestibule on touch or attempted vaginal entry and tenderness to pressure localized within the vulvar vestibule.<sup>14</sup> Enrollment was limited to women using an effective form of contraception, women who were postmenopausal, or had been surgically sterilized. Women were excluded if they had previous vestibulectomy, had generalized vulvodynia (constant vulvar pain, unrelated to provocation), had known hypersensitivity to heparin or enoxaparin, a positive pregnancy test, were pregnant or lactating, or planned to become pregnant during the previous study period. Women were also excluded from the previous study if they were chronic users of narcotics, had hepatic disease or clinically significant abnormal liver function tests, anticipated not being available for the entire duration of the previous study, had any coexisting significant medical condition that was likely to interfere with previous study procedures (e.g., cardiovascular, hematologic, central nervous system, pulmonary, renal). The patients were randomly and blindly assigned to self-administer either 40 mg of enoxaparin or saline subcutaneously in the abdominal region every day for 3 months.

For the present study, patients' files were retrieved and examined. In addition, the women were contacted by telephone and asked to complete a questionnaire designed for the present

study that examined quality of life measures using the 6 levels patient global impression of improvement (PGI-I). The pain level was assessed using the Numeric Rating Scale 0–10, frequency of intercourse per month, and treatment satisfaction. This questionnaire allowed us to compare changes over time. The first author, who made the interviews was uninvolved with the previous care of the women. He also analyzed the data with the statistician. The first author was blind of the patient treatment until the completion of the interview. In addition, the women were still blind of the previously administrated treatment at the time of the present study. Therefore, the present study is a transversal, monocentric, blinded, observational study realized on a cohort of 31 patients previously included in a randomized control trial.

**Present study variables**

The dependent variables were treatment satisfaction, pain level and frequency of intercourse, and the independent variable was treatment with enoxaparin.

**The primary outcomes:** Pain level in various aspects – pain during intercourse, pain after intercourse, finger touching the introitus, tampon insertion, riding bicycles or horses, wearing tight pants, sitting with crossed legs, urination - with no association to intercourse, urination after intercourse, and frequency of intercourse per months.

**The secondary outcomes:** The proportion of women who have an intimate partner, describing a high and very high satisfaction from treatment, the treatments received by the patients during the 3 years between the end of the previous study and the present study.

**Statistical analysis**

Data are presented as mean with standard deviation, median with the range, or proportions. In each group, changes over time were examined using paired-sample t-test or Wilcoxon signed rank test. We used an independent-sample t-test or Wilcoxon rank-sum test to compare continuous variables between groups at a given time point. We compared categorical and ordinal variables between groups using a  $\chi^2$  test or Fisher’s exact test. Based on a sample size of 14 women per group, using a paired-sample t-test with a significance of 5%, we calculated that we had 88% power to detect a 20% reduction in pain levels during intercourse from the end of the previous study, which represents significant symptom improvement.

**RESULTS**

The present study took place from January to June 2014. Thirty one of the 39 (79%) women from the previous study participated (Figure 1). The other eight were not located; 17 of the 31 were treated with 40 mg enoxaparin (enoxaparin group), and 14

received saline (placebo group). Table 1 shows that the mean age of the women was 28.0 years of age in the enoxaparin group and 28.4 in the placebo group (p=0.58).

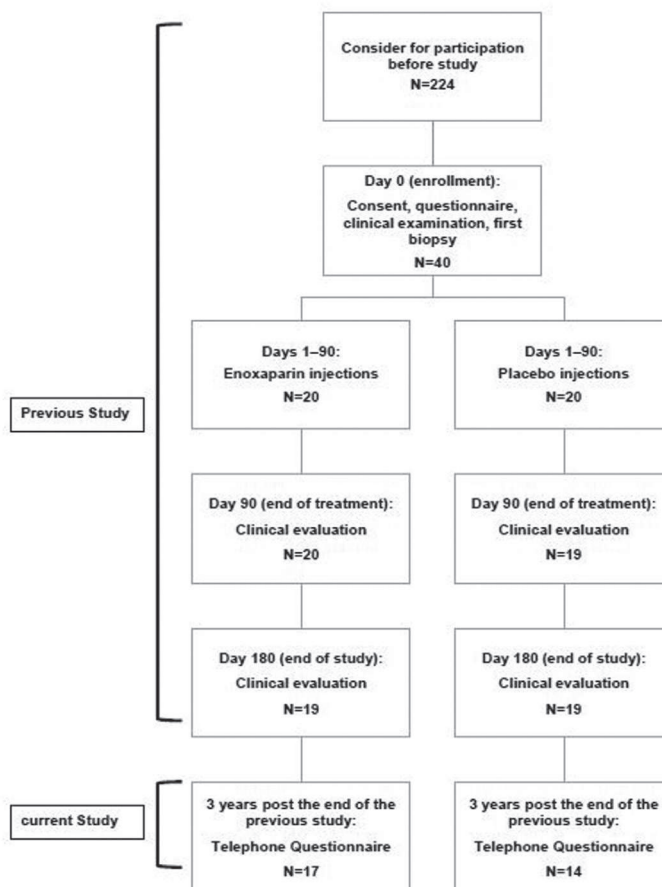

**Figure 1.** Flow chart of the previous and present study  
N: Number

Table 1. Patients characteristics			
	Placebo	Enoxaparin	p-value
Number of women	14	17	-
Age - range	23–36	24–34	-
Age - mean (SD)	28.4 (2.9)	28.0 (3.0)	0.58+
Age - median	28.0	28.0	-
Having intimate relationship (%)	11 (79%)	14 (82%)	1.00*
High and very high satisfaction from treatment	3 (21.49%)	6 (35.3%)	0.329*
Undergone additional treatment since first study (%)	7 (50%)	8 (47.1%)	1.00*
Failure of study treatment - reason for additional treatment	6/7 (87.5%)	2/8 (25%)	0.056++

SD: Standard deviation; +: Wilcoxon rank sum test; 2-sided; \*: Fisher exact test; 2-sided; ++: Chi-square test

The primary outcomes: 21.5% of women treated with saline reported significant to very significant improvement compared to 35.3% of those treated with enoxaparin ( $p=0.329$ ) (Table 1) Table 2 shows that when compared to the end of the previous study, women treated with enoxaparin reported a greater decrease in pain levels during intercourse than patients treated with placebo [34.5% versus 22.5%: the average pain level decreased from the end of the previous study until the present study, from 7.25 (SD=2.2) to 4.74 (SD=3.1)] in the enoxaparin group ( $p=0.012$ ), and from 7.1 (SD=2.6), to 5.45 (SD=2.5) in the placebo group ( $p=0.064$ ). Data shown here are paired such that baseline data only includes women who responded to the present survey.

In addition, there was a trend towards a larger decrease in pain levels among women treated with enoxaparin compared to women treated with placebo, during vestibular touch with a finger (enoxaparin: 33.3% decrease,  $p=0.052$ ; placebo: 23.7% decrease,  $p=0.081$ ); pain while riding a bicycle or horse (enoxaparin: 40% decrease, placebo: 23% increase,  $p=0.2$ ), and pain with voiding (enoxaparin: 80.6% decrease; placebo: 32.5% increase in pain,  $p=0.785$ ) (Data not tabulated). There was no difference in pain levels between the groups for voiding after intercourse, and both groups exhibited slight increases in pain levels compared to the end of the previous study. There was no difference in intercourse frequency between the groups ( $p=0.867$ ). The data indicate that women treated with enoxaparin experienced a significantly greater decrease in pain levels during intercourse, as well as during other activities listed in the questionnaire, compared to women treated with placebo. Figure 2a-c show comparisons between the three different time points of the onset of the previous study, the end of the previous study, and the end of the present study, as well as an additional comparison of only the women who participated in the previous study and responded to the present study. They depict that women treated with

enoxaparin reported a larger decrease in pain during intercourse and other activities such as tampon insertion, bicycle riding, and voiding after intercourse than women who received placebo.

The secondary outcome - the proportion of women who have an intimate partner, describing a high and very high satisfaction from treatment, and those who underwent additional treatments since the end of the previous study was similar in both treatment groups. The detailed results are: Eight (47.1%) of the 17 women in the enoxaparin group and seven of the 14 (50%) in the placebo group underwent additional treatments ( $p=1.00$ ). However, the reason the women gave for undergoing additional treatment was treatment failure in 85.7% of patients of the placebo group compared to 25% of the enoxaparin group ( $p=0.056$ ). The additional treatments that the women underwent were topical cream application, low oxalate diet, oral neuropathic treatments, acupuncture, physical therapy, or vestibulectomy.

## DISCUSSION

The present study examined the effect of enoxaparin on women suffering from provoked vulvodynia 3 years after treatment. The main finding is that compared to women receiving placebo, treated patients experienced a decrease in pain during intercourse and in vestibular touch with a finger, in the time between the end of the previous study and the present study. Enoxaparin treatment also showed a non-significant tendency towards improvement in pain levels during other activities, including tampon insertion, bicycle or horse riding, and voiding without intercourse. Additional support for the long-lasting effectiveness of enoxaparin comes from the finding that most women in the placebo group returned for additional treatments during the 3-year period prior to the present study as compared to only one quarter of women treated with enoxaparin. These findings are supported by our sensitivity analysis restricted to

**Table 2. Comparison of the vestibulodynia characteristics between the end of the previous study to the end of the current study**

	Findings	Placebo (N=14)	Enoxaparin (N=17)	1-sided p-value		2-sided p-value
Pain during intercourse	Average pain level at end of previous study (SD)	7.1 (2.6)	7.25 (2.2)	-		-
	Average pain level at end of current study (SD)	5.45 (2.5)	4.74 (3.1)	-		-
	Average decrease in pain (SD)	1.6 (2.7)	2.5 (3.7)	-		*0.427
	% decrease in pain from end of previous study to end of current study	22.5%	34.5%	Placebo: *0.064	Enoxaparin: *0.012	-
	% women with a decrease >20%	45.5%	62.5%	-		++0.452
	% women with a decrease >30%	36.4%	43.8%	-		++1.00

SD: Standard deviation; \*: Fisher's exact test, ++: Wilcoxon rank sum test

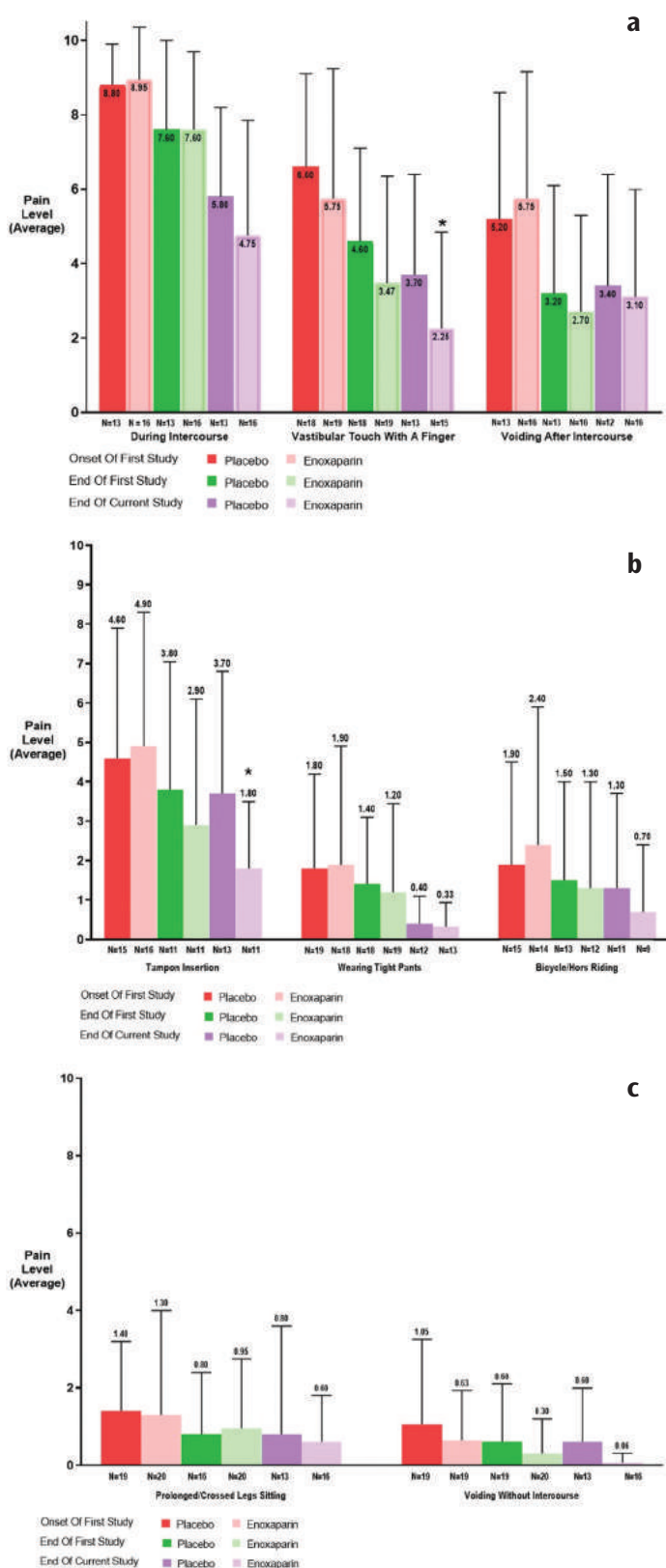

**Figure 2a-c.** Comparison of pain levels of women suffering from provoked vulvodynia during intercourse and other activities at three time points: onset of previous study, end of previous study, end of present study.  
 Legend to Figure 2a: \* $p < 0.05$ ; N: Number

only women who answered the same questions in both studies. The fact that pain levels in the treatment group unexpectedly continued to decrease up until the end of the present study, three years after treatment completion, suggests that not only is enoxaparin effective at treating provoked vulvodynia, but that it may promote healing as well, or, that by blocking heparanase, new neuroproliferation into the epithelium subsided, so that allodynia gradually diminished. The present study is the first to examine the long-term efficacy of enoxaparin as a treatment for provoked vulvodynia.

One of the parameters we tested as a marker for successful long-term treatment is the reason why patients sought additional treatments. While a similar proportion of women in both groups sought additional treatments, over three-quarters of the placebo group were referred due to a complete lack of symptom alleviation, as compared to only one quarter of the patients treated with enoxaparin that received additional treatment for mild residual discomfort. This suggests that, even 3 years after completion of treatment, enoxaparin continues to improve quality of life and sexual function.

The physiological basis for the efficacy of enoxaparin for treatment of provoked vulvodynia originated from the observation of proliferation and infiltration of neurons into the epithelium of affected patients, which leads to increased pain sensitivity.<sup>10-12</sup> These findings, together with an observed increase of mast cells, raised the hypothesis that heparanase secretion from mast cells allows the infiltration of neurons into the epithelium and the stroma.<sup>10,11</sup> The previous study tested whether blocking heparanase activity with enoxaparin would alleviate pain. Indeed, the previous study found significant symptom improvement following a short-term treatment of 3 months.<sup>12</sup> The present study examined the long-term effects of this treatment and found that the positive effect of enoxaparin is sustained for at least 3 years. This result strengthens the idea that blocking heparanase treats the etiology of provoked vulvodynia. As a next step, it will be helpful to examine similar, yet more specific, heparanase blockers. In order to examine whether enoxaparin affects the tissue itself over the long term, biopsies of women treated with enoxaparin should be obtained 3 years after treatment and be histologically examined for free nerve fiber endings and mast cell number. This can then be compared to biopsies taken at the end of the previous study.

In order to assess treatment efficacy, enoxaparin must be compared to other treatments for provoked vulvodynia. Treatment of provoked vulvodynia usually begins with medications, either locally or orally administered. One pharmaceutical option is Amitriptyline, yet most studies have

been unable to show any significant increase in quality of life or decrease in pain levels following treatment.<sup>15</sup> In addition, side effects of Amitriptyline treatment, including trouble concentrating, tachycardia, hypotension, seizures, constipation, dry mouth and urinary retention, present significant drawbacks. Surgical vulvar vestibulectomy is currently the most effective treatment and will usually be recommended after failure of less invasive measures. One study demonstrated a significant decrease of pain during intercourse and an increase in sexual activity in 90% of surgically treated patients.<sup>16</sup> However, some patients report worsening of their condition, including pain reoccurrence, vaginal dryness and Bartholin's duct occlusion, which are conditions requiring additional surgery.<sup>17</sup> The findings of the present study place enoxaparin as a possible effective alternative to surgical intervention.

One less encouraging result of the present study is the fact that treatment was effective in only a portion of patients. This suggests that provoked vulvodynia may be a multi-causal disease and that enoxaparin is effective only in a subset of patients.

The present study's main advantage is the long-term evaluation of a novel treatment of provoked vulvodynia and comparing two groups that were originally randomized to treatment and control groups. One drawback of the present study is that the average age of the participants was young, with mean age 28 (enoxaparin group) to 28.4 (placebo group) years old, and they all suffered from severe provoked vulvodynia. Therefore, results may be different in older patients and/or in patients suffering from a less severe form of the disease.

Another advantage is that the interviews were made by a researcher who was uninvolved with the primary care of the women. This prevented a bias that might have been introduced if women wanted not to offer disappointing answers to the primary researcher who followed them during the previous study.

A limitation of the present study is that it is a relatively small study, the evaluation was made by using questionnaires only, and no new biopsies were made. During the three years, women had different interventions to try to control the pain. Not all patients who participated in the previous study were located. However, 79% were found. This significant rate assures that the findings of the present study are highly reliable.

## CONCLUSION

The present study shows that women with severe provoked vulvodynia who had previously participated in a three-month trial comparing enoxaparin to placebo for the treatment of provoked vulvodynia were contacted three years later with self-

questionnaire reported less pain with intercourse if they were in the enoxaparin group. If other studies substantiate this finding, enoxaparin may have an implication for women suffering from provoked vulvodynia.

## Contributions

Surgical and/or Medical Practices: E.O., E.P., J.B., Concept: E.O., E.P., J.B., Design: E.O., E.P., J.B., Data Collection or Processing: E.O., E.P., J.B., Analysis or Interpretation: E.O., E.P., J.B., Literature Search: E.O., E.P., J.B., Writing: E.O., E.P., J.B.

## Ethics

**Ethics Committee Approval:** The present study was approved by the Institutional Review Board (IRB) of the Galilee Medical Center of the Israeli Health Ministry, on June 2<sup>nd</sup>, 2013. Authorization number: 0039-13-NHR.

**Informed Consent:** Written informed consent was obtained from all subjects.

**Peer-review:** Externally peer-reviewed.

## DISCLOSURES

**Conflict of Interest:** No conflict of interest was declared by the authors.

**Financial Disclosure:** The authors declared that this study received no financial support.

## REFERENCES

- Bergeron S, Reed BD, Wesselmann U, Bohm-Starke N. Vulvodynia. *Nat Rev Dis Primers* 2020; 6: 36.
- Gerber S, Bongiovanni AM, Ledger WJ, Witkin SS. Interleukin-1beta gene polymorphism in women with vulvar vestibulitis syndrome. *Eur J Obstet Gynecol Reprod Biol* 2003; 107: 74-7.
- Jeremias J, Ledger WJ, Witkin SS. Interleukin 1 receptor antagonist gene polymorphism in women with vulvar vestibulitis. *Am J Obstet Gynecol* 2000; 182: 283-5.
- Pyka RE, Wilkinson EJ, Friedrich EG Jr, Croker BP. The histopathology of vulvar vestibulitis syndrome. *Int J Gynecol Pathol* 1988; 7: 249-57.
- Foster DC, Piekarczyk KH, Murrant TI, LaPoint R, Haidaris CG, Phipps RP. Enhanced synthesis of proinflammatory cytokines by vulvar vestibular fibroblasts: implications for vulvar vestibulitis. *Am J Obstet Gynecol* 2007; 196: 346.e1-8.
- Glazer HI, Rodke G, Swencionis C, Hertz R, Young AW. Treatment of vulvar vestibulitis syndrome with electromyographic biofeedback of pelvic floor musculature. *J Reprod Med* 1995; 40: 283-90.
- Harlow BL, Vitonis AF, Stewart EG. Influence of oral contraceptive use on the risk of adult-onset vulvodynia. *J Reprod Med* 2008; 53: 102-10.

8. Tarr G, Selo-Ojeme DO, Onwude JL. Coexistence of vulvar vestibulitis and interstitial cystitis. *Acta Obstet Gynecol Scand* 2003; 82: 969.
9. Babula O, Bongiovanni AM, Ledger WJ, Witkin SS. Immunoglobulin E antibodies to seminal fluid in women with vulvar vestibulitis syndrome: relation to onset and timing of symptoms. *Am J Obstet Gynecol* 2004; 190: 663-7.
10. Bornstein J, Goldschmid N, Sabo E. Hyperinnervation and mast cell activation may be used as histopathologic diagnostic criteria for vulvar vestibulitis. *Gynecol Obstet Invest* 2004; 58: 171-8.
11. Bornstein J, Cohen Y, Zarfati D, Sela S, Ophir E. Involvement of heparanase in the pathogenesis of localized vulvodynia. *Int J Gynecol Pathol* 2008; 27: 136-41.
12. Farajun Y, Zarfati D, Abramov L, Livoff A, Bornstein J. Enoxaparin treatment for vulvodynia: a randomized controlled trial. *Obstet Gynecol* 2012; 120: 565-72.
13. Marinoff SC, Turner ML. Vulvar vestibulitis syndrome: an overview. *Am J Obstet Gynecol* 1991; 165: 1228-33.
14. Friedrich EG Jr. Vulvar vestibulitis syndrome. *J Reprod Med* 1987; 32: 110-4.
15. Schmidt S, Bauer A, Greif C, Merker A, Elsner P, Strauss B. Vulvar pain. Psychological profiles and treatment responses. *J Reprod Med* 2001; 46: 377-84.
16. Gaunt G, Good A, Stanhope CR. Vestibulectomy for vulvar vestibulitis. *J Reprod Med* 2003; 48: 591-5.
17. Schneider D, Yaron M, Bukovsky I, Soffer Y, Halperin R. Outcome of surgical treatment for superficial dyspareunia from vulvar vestibulitis. *J Reprod Med* 2001; 46: 227-31.



# Diagnosis and pathophysiology of Hirschsprung's disease

✉ MICHAEL D. LEVIN<sup>1,2</sup>

<sup>1</sup>Department of Pediatric Radiology of the 1<sup>st</sup> State Hospital, Minsk, Belarus

<sup>2</sup>Dorot-Netanya Geriatric Medical Center, Israel

## ABSTRACT

**Objective:** The aim of this research was to study the X-ray findings of Hirschsprung's disease (HD) based on analysis of radiographs and videos published on the Internet and our own research, in order to increase the accuracy of X-ray diagnosis HD.

**Materials and Methods:** An analysis of 56 radiographs and 2 videos of patients with a histologically confirmed diagnosis of HD was performed, including 25 radiographs from our own practice and 31 radiographs and 2 videos from articles published in PubMed and PMC. For comparison, cases without HD were compared, including radiographs from the author's practice, where HD was excluded based on manometric detection of rectoanal inhibitory reflex (RAIR). For X-ray analysis, a contrast marker of known diameter was used, which was located near the anus.

**Results:** In addition to the signs already described in the literature (the transition zone, microcolon, retention of contrast on post evacuation film, and the rectosigmoid ratio <1), we propose new anatomical signs of HD, i.e. the absence of an anterior displacement of the anal canal axis, an expansion of the retro-rectal space, and symptom of "frozen" segmentation. In addition, we suggest novel physiological diagnostic signs, i.e. the absence of the RAIR and defecation reflex.

**Conclusion:** The combination of these signs makes it possible to diagnose HD. Shortening of the anal canal, with a noticeable displacement of it towards the pubis, as well as the presence of RAIR and wide opening of the anal canal during rectal emptying indicate the absence of HD. The use of these signs increases the accuracy of the HD diagnosis. An algorithm of diagnostics is offered.

**Keywords:** Anal manometry; Hirschsprung's disease; congenital aganglionosis; x-ray diagnosis

## INTRODUCTION

Hirschsprung's Disease (HD) is relatively common in children. Surgical treatment is aimed at removing the aganglionic section of the gut and repairing the intestinal tract. Despite some achievements of recent years, the diagnosis of the disease is not always timely. After surgical correction, functional problems may arise.<sup>1</sup> The final diagnosis of HD is based on rectal biopsy. Nevertheless, the diagnostic process may involve a contrast barium enema, which in some cases allows to reject the putative diagnosis of HD, and in 70%–90% of cases establish the location

of the transition zone.<sup>2</sup> Some authors recommended the use a manometric study to exclude HD, but its use is recently decreasing.<sup>3</sup>

During normal early embryonic development, the nerve cells invade the primary intestine in a craniocaudal direction. The enteric ganglia are interconnected to form two plexuses that extend along the length of the bowel: an outer myenteric (Auerbach) plexus - running through the full length of the gut, and an inner submucosal (Meissner) plexus, found only in the small and large intestine. The myenteric plexus develops first and

**Address for Correspondence:** Michael Levin, Department of Pediatric Radiology, 1<sup>st</sup> State Hospital, Minsk, Belarus; Dorot-Netanya Geriatric Medical Center, Israel  
**E-mail:** nivel70@hotmail.com **ORCID:** orcid.org/0000-0001-7830-1944

**Received:** 11 May 2021 **Accepted:** 11 May 2021

©Copyright 2021 by the International Society for Pelviperineology / Pelviperineology published by Galenos Publishing House.



is situated between the longitudinal and circular smooth muscle layers. It is involved in intestine motility, while the submucosal plexus, which is formed later, regulates motility, blood flow, and the transport of ions across the intestinal epithelium.<sup>4</sup>

Gut motility is controlled by interdependent mechanisms including neural, such as the enteric ganglia, and nonneural, such as the interstitial cells of Cajal (ICC).<sup>4,5</sup> The ICC serve as pacemaker cells creating and propagating slow waves that lead to smooth muscle contraction in the gut.<sup>4</sup>

The absence of enteric ganglion cells of the myenteric and submucosal plexus along variable portions of the gastrointestinal tract results in HD, which is characterized by sustained contraction of the aganglionic bowel segment, leading to intestinal obstruction and distension of proximal segments (megacolon). No matter how far from the anus the aganglionic segment begins, it always reaches the middle of the anal canal. The gold standard for an HD diagnosis is a rectal biopsy.<sup>5</sup>

In 80%–85% of HD cases, the aganglionic region is limited to the rectum and sigmoid colon. Long segment disease occurs in up to 20% of cases and is characterized by aganglionosis extending proximally to the sigmoid colon. Total colonic aganglionosis is rarer, occurring in 3%–8% of patients with HD. Another rare variant is ultra-short segment disease, affecting only the distal rectum ( $\leq 2$  cm).<sup>5,6</sup>

### Anorectal Manometry (ARM)

During anorectal manometry (ARM), a flexible catheter, with a non-latex balloon at its distal end, is introduced into the rectum. The sensor measures intra-anal pressures during the study. The recto-anal inhibitory reflex (RAIR) is the reflex relaxation of the internal anal sphincter (IAS) in response to rectal distention. This reflex is present in individuals with normal intrinsic innervation of the intestine (Figure 1a) and is absent in those with HD. The HD is characterized by a short-term rise in pressure in the upper anal canal in response to rectal dilatation (Figure 1b, c). The

depth and duration of the relaxation of the IAS progressively increases with the increasing in the rectal balloon volume up to 70 cm<sup>3</sup> and thereafter does not change (Figure 1c).<sup>7,8</sup> In a study by Jarvi et al.<sup>9</sup> the specificity and positive predictive value of ARM for HD were 83% and 80%, respectively. They concluded that if RAIR is present, a rectal biopsy may not be required.

Radiologic anatomical findings with contrast enema that are suggestive of HD include the presence of a radiographical transition zone with proximal dilated bowel, microcolon, retention of contrast material on the post evacuation film, irregular colonic contractions, mucosal irregularity, and an abnormal rectosigmoid ratio. The radiographic location of the transition zone has been shown to correlate with the length of the aganglionic segment, specifically of the rectosigmoid segment. The findings may aid in the surgical procedure planning. However, the correlation was low in segments proximal to the rectosigmoid colon and in children younger than 3 months of age. This further highlights the importance of intraoperative biopsies to direct surgical planning.<sup>5</sup> In a systematic review of the literature, de Lorijn et al.<sup>10</sup> reported that contrast enema had lower mean sensitivity and specificity of 70% and 83%, respectively, when compared to ARM and rectal suction biopsy. Furthermore, contrast enema in the neonatal period has been shown to be less reliable than in older children.<sup>10</sup>

### Radiologic functional findings

Nusslé et al.<sup>11</sup> showed for the first time the X-ray manifestation of the RAIR during a contrast enema in the form of penetration of the contrast medium into the upper part of the anal canal. Measurement of anal pressure during a barium enema revealed that the penetration of barium into the upper part of the anal canal in front of the tip of the enema is accompanied by a decrease in anal pressure, and after the disappearance of barium from the anal canal, anal pressure is restored to the basal level. The use of a contrast marker near the anus improves visualization of the X-ray equivalent of the RAIR.<sup>12</sup>

### Attached images

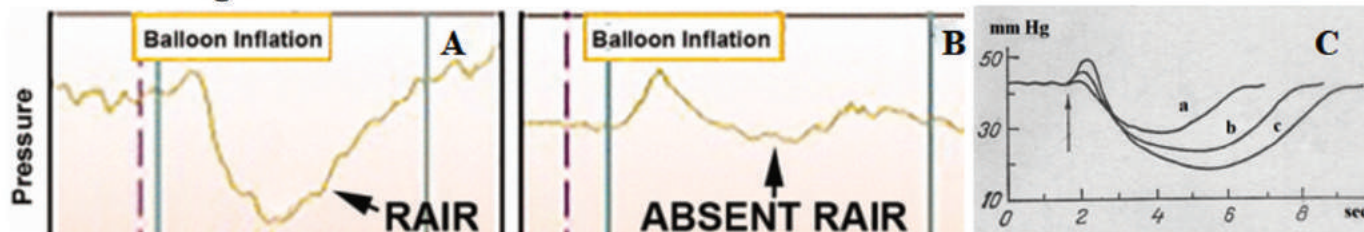

**Figure 1.** Anorectal manometry. Representative single sensor pressure tracings from different individuals with a normal RAIR (A) and a patient with HD (B). From an article by Ambartsumyan et al.<sup>5</sup> (C) Graphs anal pressure (RAIR) following rapid injection of air into the rectum: (a) 30 cm<sup>3</sup>; (b) 50 cm<sup>3</sup>; (c) 70 cm<sup>3</sup>.<sup>8</sup>

RAIR: Rectoanal inhibitory reflex

Ornö et al.<sup>13</sup> applied sonographic method for examination of the RAIR. The RAIR was elicited by injecting 20 ml water into the rectum, and the events in the bowel were recorded on video for offline analysis. Among 28 children (median age, 21 months; range, 5 days–12 years; 11 younger than 1 year and 7 between 1 and 2 years) with suspected HD, in 3 with aganglionosis, RAIR was absent. In 17 children, the RAIR was present, and all of these children had normal histologic findings. In eight children, sonography did not show the reflex despite normal histologic findings (29% false-negative results).<sup>13</sup> Vult von Steyern et al.<sup>14</sup> used an enema with Omnipaque 140 mg/ml for the differential diagnosis of chronic constipation. After the contrast medium had filled the rectum and the distal part of the sigmoid, two sequential fast (<5 s) injections of 20 ml cold contrast agent (16 °C) were performed with documentation of low pulse fluoroscopy sequences for about 30 seconds each. The contrast medium was injected until a transition zone was identified or the whole colon was filled. Five boys and one girl (median age, 7.5 days) were diagnosed with HD. The negative predictive value of the RAIR was 100%. A contrast enema with signs of HD in combination with an absent RAIR had the specificity of 98% and sensitivity of 100% for HD.<sup>14</sup>

In HD, apart from the absence of RAIR, there is no information about the function of the external anal sphincter (EAS), puborectalis muscle (PRM), and levator plates (LP). This information can be useful for improving the accuracy of the preoperative diagnosis, as well as for choosing the optimal method of surgical treatment.

The aim of this research is to study the X-ray symptomatology of HD, based on analysis of radiographs and videos published on the Internet and based on our own research to increase the accuracy of X-ray diagnosis HD.

## MATERIAL AND METHODS

An analysis of 56 radiographs and two videos of patients with a histologically confirmed diagnosis of HD was performed, including 25 radiographs from our own practice and 31 radiographs and two videos from articles published in PubMed and PMC. In 18 articles, only frontal radiographs were given. Lateral radiographs have been reported in 13 articles, mostly in the past 20 years. As examples of cases without HD, radiographs from our own practice are given, where HD was excluded based on RAIR detection in the manometric examination. For X-ray analysis, a contrast marker of known diameter was used, which was located near the anus. This made it possible to measure the length of the anal canal, as well as to determine the true parameters of different parts of the intestine, which were compared with previously published age standards.<sup>12</sup>

## RESULTS

### Frontal and lateral images

In many cases, a frontal radiograph is sufficient to diagnose HD and determine the level of the transition zone (Figure 2a). However, in some patients, a frontal radiograph may be unreliable. The short aganglionic segment may be obscured by an extended rectum. To visualize it, a lateral radiograph is required (Figure 2b).

In infants, the difference in width between healthy and aganglionic segments may be negligible. A lateral radiograph and X-ray study of the RAIR may be diagnostic (Figure 3).

### X-ray analysis

The anus is located where the contrast agent has stained the buttocks around the catheter (asterisk). The true length of the anal canal (e), located between the pubococcygeal line and the anus, is 1.7 cm at this age.<sup>15</sup> Based on this, the width of the distal rectal segment is 0.6 cm (the minimum normal limit for this age is 1.3 cm). Thus, using the radiologic analysis, the “microcolon” symptom received a digital expression. The retro-rectal space, i.e. the distance from the posterior wall of the rectum to the vertebra (red line) is 0.8 cm while the size appropriate to the age should not exceed 0.1 cm. Therefore, this finding depicts a sharp narrowing of the rectum and a sharp expansion of the retro-rectal space. Throughout the study, the axes of the rectum and the anal canal completely coincide. This means that the PRM did not contract and not pull the upper part of the anal canal anteriorly. During the emptying of the contrast medium, the rectum did not participate in this process, and there was no expansion of the anal canal, i.e. there was no contraction in levator plates. Three segments of the rectum expanded and moved caudally, but retained the same shape - a symptom of

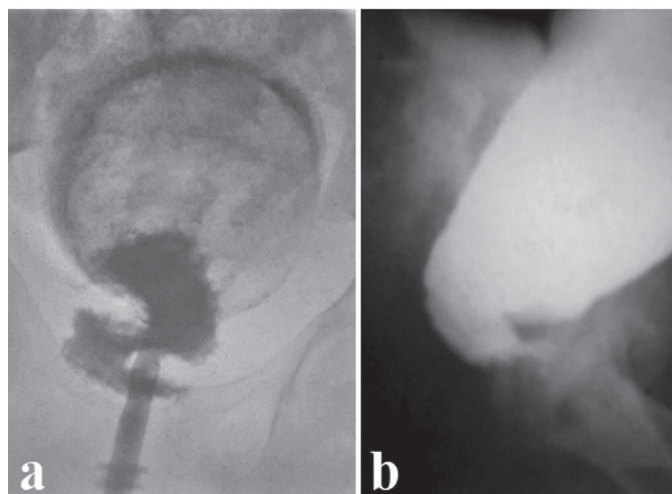

**Figure 2.** Frontal (a) and lateral (b) radiographs patients with HD  
HD: Hirschsprung's disease

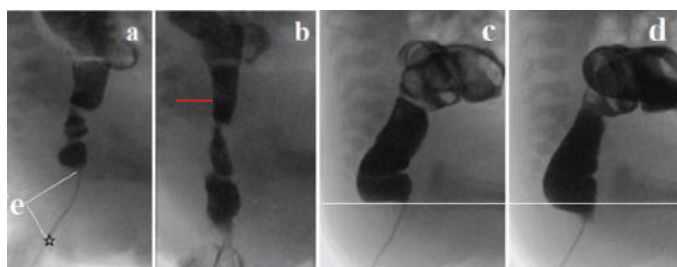

**Figure 3.** Video excerpts from von Steyern's article<sup>14</sup> with permission from the authors. A 1-month-old boy later diagnosed with Hirschsprung disease. The rectoanal inhibitory reflex is absent. At the beginning of the study (a), the contrast agent in the rectum was divided into 3 segments by circular contractions. ("e" - anal canal). The end of the catheter is located between the upper and middle segments. As a result of the introduction of a contrast agent, the volume in the lower segments increased, which indicates an increase in pressure. Then (b) segments (symptom of frozen segmentation) partially moved into the anal canal. There is a sharp expansion of the retro-rectal space (red line). (c-d) A 1-month-old boy without Hirschsprung's disease. The rectum is wide with smooth walls. The axis of the anal canal is displaced anteriorly from the rectum. During the injection of the contrast agent, it penetrated into the upper part of the anal canal (RAIR)

RAIR: Rectoanal inhibitory reflex

frozen segmentation. Consequently, emptying occurred without a defecation reflex. Thus, the lack of relaxation of the IAS was not the only symptom of HD.

This analysis indicates that in order to improve the diagnosis of HD, it is necessary to perform at least frontal and lateral radiographs. Video, frontal radiograph at 24<sup>th</sup> hours, and radiometric analysis of radiographs may confirm the diagnosis once there were doubts after standard radiography.

### The sign of the rectosigmoid ratio <1 (Figure 4).

#### X-ray analysis

In Figure 4a, the rectum proximal to the short contracted aganglionic segment (d) is narrower than the sigmoid colon, and the question may arise, is it aganglionic? Measurement shows that it is much wider than the maximum normal limit. The rectum to sigmoid ratio <1 is due to the fact that expansion of the rectum is limited by the size of the small pelvis, while the expansion of the sigmoid colon is not limited. In Figure 4b, the rectosigmoid ratio is <1 for the same reason. However, a sharp shortening of the anal canal is indicative of stretching of the pelvic floor muscles, which is called "perineal descending syndrome" - characteristic of functional constipation. In all 12 patients with HD, where it was possible to measure the length of the anal canal, including five patients with a short form of aganglionosis, the length of the anal canal was within the age norm.

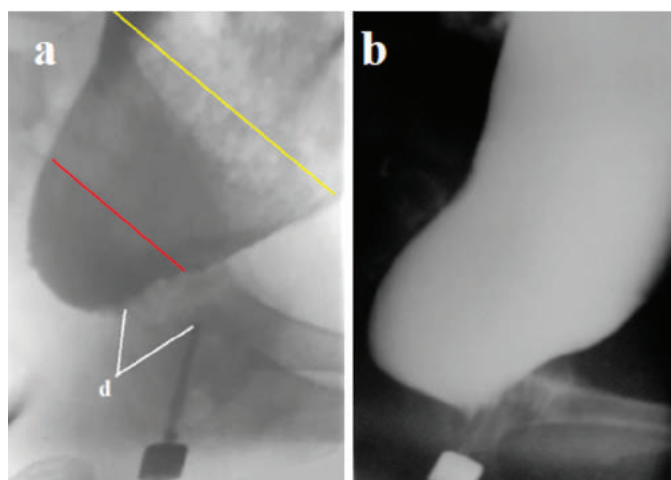

**Figure 4. (a-b)** Rectosigmoid ratio in HD and in FC. (a) A 10-year-old girl with a short (d = 2.5 cm) aganglionic segment, which is in a contracted state. The width of the rectum (red line) is 6.4 cm. A maximum age norm is 4.1 cm. The width of the sigmoid colon is 11 cm. A maximum norm is 2.6 cm). (b) An 8-year-old male with FC. He has a rectosigmoid ratio <1. However, the rectal width is 5.1 cm. It greater than the maximum normal limit (4.1 cm), and the anal canal length of 1.4 cm is significantly less than the minimum normal limit (2.6 cm)

HD: Hirschsprung's disease; FC: Functional constipation

Analysis of radiographs shows that expansion of the rectum above the normal limit in combination with shortening of the anal canal may be characteristic only of functional constipation and not of HD.

Irregular colonic contractions and mucosal irregularity are optional signs of HD. Colonic and/or rectal narrowing and segmentation, as well as mucosal irregularity, may be signs of enterocolitis. Enterocolitis is a sequela of intestinal obstruction and in turn, makes it worse. Usually, not all segments of the intestine are narrowed and involved in the inflammatory process. Consequently, the rectum may have a normal width and contour (Figure 5a). However, its shape differs sharply from the normal one. Due to the absence of nerve ganglia in the rectum, an increase in pressure in it does not cause relaxation of the IAS and does not cause a reflex contraction of the PRM and EAS. As a result, there is no dislocation of the lower part of the rectum forward and no horizontal branch of the rectum is formed.

The aganglionic segment of the intestine may be in a spastic state during the inflammatory process. Without enterocolitis, its width can be within normal limits. In such cases, the sigmoid colon is expanded due to stasis of the stool throughout the rectum since there is no peristalsis in it. In HD, unlike functional constipation, the rectum is not dilated, the length of the anal canal is not shortened and there is no RAIR. An additional symptom of HD is the lack of signs of PRM contraction. Normally, the axis of the anal canal coincides with the rectal axis only in

infants. In older children, the periodic contraction of the PRM pulls the upper part of the anal canal toward the pubis during the fecal retention. Then, a horizontal branch of the rectum is formed, the axis of the anal canal is displaced anteriorly and an acute recto-anal angle may be formed (Figure 5b). Four patients demonstrated an absence of a horizontal branch of the rectum with merge of the axes of the rectum and the anal canal. They all had a rectosigmoid ratio  $<1$ . The rectum was not narrow but not above the normal limits. We consider this combination of signs typical for HD because in our practice we have never observed it with other diseases. These findings may suggest that the rectum is not connected by nerve pathways with the PRM and therefore the expansion of the rectum does not cause a reflex contraction of the PRM, as it normally happens about seven times per hour.

In four patients with HD, the radiographs show a small displacement of the anal canal axis anterior to the rectum (Figure 5c) with a short horizontal rectal ramus. This is because the posterior wall vertical branch of the rectum remains next to the coccyx, while with age, the size of the perineum increases, and the distance between the coccyx and the anus increases. If the rectum had a normal width, then the axis of the anal canal would pass through the rectum. The measurement of the horizontal distance between the last coccygeal vertebra and the ano-rectal junction was found to be the same in patients with HD of the same age (see Figures 5b, c - red line). The presence of an ano-rectal angle of more than 90 degrees in each case, confirms the assumption that there is no contraction in the PRM.

In HD, unlike as in functional constipation, the rectum is not dilated, the length of the anal canal is not shortened and there is no RAIR. An additional radiologic sign of HD is the lack of signs of PRM contraction: (1) the absence of a horizontal branch of the rectum with the coincidence of the axes of the rectum and

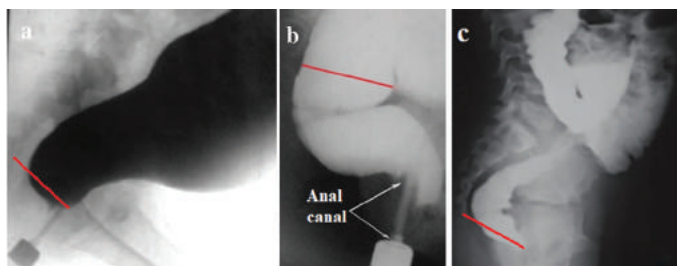

**Figure 5.** Lateral radiographs of the ano-rectum of patients at the age of 4–6 years. The true diameter of the marker located near the anus is 1.6 cm. IAS: Internal anal sphincter; RAIR: Rectoanal inhibitory reflex; HD: Hirschsprung's disease; Prm: Puborectalis muscle

the anal canal; (2) the absence of a penetration of contrast agent into the anal canal in front of the tip of the enema. These signs also suggest that the aganglionic rectum is not connected by nerve pathways with the PRM.

## DISCUSSION

As shown in a systematic review de Lorigj et al.<sup>10</sup>, the sensitivity and specificity of contrast enema (12 studies for a total of 425 patients) were significantly lower than those of anorectal manometry and rectal suction biopsy, with mean sensitivity and mean specificity of 70% and 83%, respectively. According to Wong et al.<sup>18</sup>, the sensitivity of the 24 hours of delayed film was 85.7 % and the specificity was 17.6%. The diagnosis of HD is actually based on four radiologic anatomical signs: A transition zone with proximal dilated bowel, microcolon, retention of contrast in the post evacuation film, and an abnormal rectosigmoid ratio ( $<1$ ). As shown above, none of these signs are 100% reliable. An increase in the diagnostic accuracy of a contrast enema can be achieved in three ways: (1) optimization of the examination program; (2) comparison of radiographic images of ano-rectum with normal specimens of anorectal anatomy; (3) studies of anorectal reflexes.

### Optimization of the patient examination program includes the following provisions

a) Contrast agent. For chronic constipation with signs of acute deterioration, a water-soluble contrast agent is preferred. In other cases - a barium enema.

b) Using a contrasting mark of a known diameter on the tip of the enema, which touches the anus allows to measure the length of the anal canal, determine the location of its axis, and use radiometric analysis to compare the obtained data with age standards.<sup>1</sup> This made it possible to define the concept of "microcolon" as the width of the rectum and of the colon is less than the minimum age limit.<sup>2</sup> A decrease in the length of the anal canal relative to the minimum age limit makes it possible to reliably exclude HD.<sup>3</sup> The absence of the lower horizontal branch of the rectum in a patient older than a year, is characteristic of HD at the non-dilated rectum, and the rectosigmoid ratio  $<1$ .

c) The lateral radiograph and/or the video recording, allows to fixate the relaxation of the IAS (RAIR).<sup>4</sup> Penetration of the contrast agent into the anal canal in front of the enema tip indicates relaxation of the BAC. This is aradiologic manifestation of the RAIR. The presence of the reflex reliably excludes HD, to the same extent as in ano-rectal manometry. At the same time, the reliability of the radiologic functional method for determining RAIR is not inferior to the manometric method, and even surpasses it. In a study by Jarvi et al.<sup>9</sup>, the specificity and positive predictive value of ARM for HD were 83% and 80%, respectively. A contrast enema with signs of HD in combination with an absent RAIR had the specificity of 98% and sensitivity of 100% for HD.<sup>14</sup>

d) If on the radiograph after emptying and/or after 24 hours, the contrast agent remains above a narrow or spasmodic intestinal

segment, this is suspicious of HD. However, if this is combined with the symptom of “frozen” segmentation, i.e., segmentation of the intestine that does not change over time, it indicates the absence of peristalsis and therefore is a convincing sign of HD. As can be seen from Table 1, a combination of several signs increases the accuracy of the differential diagnosis between HD and functional constipation (“without Hirschsprung’s disease”). At the same time, the detection of normal anorectal reflexes (RAIR and/or defecation reflex) allows excluding HD and avoiding rectal biopsy.

## CONCLUSION

As shown by numerous studies, four radiologic anatomical signs [transition zone with proximal dilated bowel, microcolon, retention of contrast on post evacuation film, and an abnormal rectosigmoid ratio (<1)] have low sensitivity and specificity in the differential diagnosis of the HD and functional constipation. The use of the X-ray functional signs described by us increases the

reliability of X-ray diagnostics. The present study has shown that the aganglionic rectum does not have neural connections with anorectal sphincters. Therefore, an increase in rectal pressure does not induce relaxation of the IAS, a contraction of the PRM, external anal sphincter, and levator plates.

## Ethics

**Ethics Committee Approval:** Ethics committee approval is not necessary for this type of studies.

**Informed Consent:** Since this study does not involve human subjects informed consent is not necessary.

**Peer-review:** Externally peer-reviewed.

## DISCLOSURES

**Financial Disclosure:** The author stated that they had no relevant financial interests or personal affiliation.

**Table 1. Significance of radiologic signs in diagnosis of Hirschsprung’s disease**

X-ray symptoms	Hirschsprung’s disease		Without Hirschsprung’s disease
	100%	Doubtful symptom	100%
Obvious transition zone with distal microcolon	x		
Rectosigmoid index <1 with non-dilated rectum	x		
Rectosigmoid index <1 with dilated rectum		x	
Rectosigmoid index <1 with dilated rectum and anal canal shortening			x
Rectosigmoid index <1 without horizontal branch of the rectum	x		
Symptom of “frozen” segmentation	x		
Expansion of the retro-rectal space		x	
Shortening of the anal canal			x
Relaxation of IAS (RAIR)			x
Defecation reflex (wide opening of the anal canal)			x

IAS: Internal anal sphincter; RAIR: Rectoanal inhibitory reflex

## REFERENCES

1. Langer JC. Hirschsprung disease. *Curr Opin Pediatr* 2013; 25: 368-74.
2. Butler Tjaden NE, Trainor PA. The developmental etiology and pathogenesis of Hirschsprung disease. *Transl Res* 2013; 162: 1-15.
3. Pratap A, Gupta DK, Tiwari A, et al. Application of a plain abdominal radiograph transition zone (PARTZ) in Hirschsprung's disease. *BMC Pediatr* 2007; 7: 5.
4. Butler Tjaden NE, Trainor PA. The developmental etiology and pathogenesis of Hirschsprung disease. *Transl Res* 2013; 162: 1-15.
5. Ambartsumyan L, Smith C, Kapur RP. Diagnosis of Hirschsprung Disease. *Pediatr Dev Pathol* 2020; 23: 8-22.
6. Kessmann J. Hirschsprung's disease: diagnosis and management. *Am Fam Physician* 2006; 74: 1319-22.
7. Cheeney G, Nguyen M, Valestin J, Rao SS. Topographic and manometric characterization of the recto-anal inhibitory reflex. *Neurogastroenterol Motil* 2012; 24: e147-54.
8. Levin MD. Function of the anorectal zone in norm and in Hirschsprung disease. *Zdravookhraneniye Belorussii* 1986; 5: 30-3.
9. Jarvi K, Koivusalo A, Rintala RJ, Pakarinen MP. Anorectal manometry with reference to operative rectal biopsy for the diagnosis/exclusion of Hirschsprung's disease in children under 1 year of age. *Int J Colorectal Dis* 2009; 24: 451-4.
10. de Lorijn F, Kremer LC, Reitsma JB, Benninga MA. Diagnostic tests in Hirschsprung disease: a systematic review. *J Pediatr Gastroenterol Nutr* 2006; 42: 496-505.
11. Nusslé D, Genton N, Bozic C. Functional radiological findings in Hirschsprung's disease and in other cases of dyschezia. *Ann Radiol (Paris)* 1976; 19: 111-22.
12. Levin MD, Korshun Z, Mendel'son G. [The method of radiographic examination anorectal area]. *Eksp Klin Gastroenterol* 2011; (12): 15-21.
13. Ornö AK, Lökvist H, Marsál K, von Steyern KV, Arnbjörnsson E. Sonographic visualization of the rectoanal inhibitory reflex in children suspected of having Hirschsprung disease: a pilot study. *J Ultrasound Med* 2008; 27: 1165-9.
14. Vult von Steyern K, Wingren P, Wiklund M, Stenström P, Arnbjörnsson E. Visualisation of the rectoanal inhibitory reflex with a modified contrast enema in children with suspected Hirschsprung disease. *Pediatr Radiol* 2013; 43: 950-7.
15. Levin MD. Reaction to Koppen et al., 'Assessing colonic anatomy normal values based on air contrast enemas in children younger than 6 years'. *Pediatr Radiol* 2018; 48: 1674-7.
16. Levin MD. The role of the external anal sphincter in the physiology of the pelvic floor. *Pelviperineology* 2017; 36:108-12.
17. Ouladsaiad M. How to manage a late diagnosed Hirschsprung's disease. *Afr J Paediatr Surg* 2016; 13: 82-7.
18. Wong CW, Lau CT, Chung PH, Lam WM, Wong KK, Tam PK. The value of the 24-h delayed abdominal radiograph of barium enema in the diagnosis of Hirschsprung's disease. *Pediatr Surg Int* 2015; 31: 11-5.



# Removal time of postoperative vesical catheter in utero-vaginal prolapse surgery: a comparative study

EDGARDO CASTILLO-PINO, NATALIA BENAVIDES, VALENTINA ACEVEDO, VALERIA ALONSO

Pelvic Floor Unit, Department of Obstetrics and Gynaecology, University of the Republic School of Medicine, Clinical Hospital, Montevideo, Uruguay

## ABSTRACT

**Objective:** To assess the efficacy and complications of early, intermediate, or late removal of the urinary catheter after vaginal hysterectomy, pelvic floor repair and anterior colporrhaphy.

**Materials and Methods:** Seventy-three Women with primary uterine or vaginal prolapse  $\geq$  stage II according to Pelvic Organ Prolapse Quantifications System without stress urinary incontinence and without recurrent urinary tract infections, candidates for vaginal repair surgery were included. A urinary catheter (Foley 16) was inserted at the time of the intervention and it was removed at random in three groups, 24 (27 patients), 48 (23 patients) and 72 hours (23 patients) after surgery. Prophylactic intravenous antibiotics were administered for 72 hours. Urinary tract infection (UTI) was diagnosed by urine culture after surgery and acute urinary retention (AUR) during hospitalization. Percentage frequencies were calculated, and the chi-square test ( $\chi^2$ ) was used to search for differences.

**Results:** UTI was observed in 7.4%, 17.4% and 13% in groups 1, 2 and 3 respectively. No statistically significant association was found between the presence of UTI and urinary catheterization time ( $\chi^2=1.3$   $p=0.512$ ). AUR was found in 4.1% of all patients, most of them from group 2.

**Conclusion:** Early removal of the urinary catheter in the first 24 hours after vaginal surgery decreased catheterization time, hospital stay and urinary tract infection. Extended catheterization does not offer benefits to patients and prolongs hospital stay unnecessarily.

**Keywords:** Urinary catheter; prolapse; vaginal surgery; urinary tract infection; post-operative urinary retention; urine culture

## INTRODUCTION

Vaginal reconstruction surgery in pelvic organ prolapse (POP) has its own intra-operative complications, such as bleeding, vaginal infection, bladder, ureteral, or intestinal injury; and postoperative complications, such as febrile morbidity, urinary retention, and urinary tract infections.<sup>1,2</sup>In vaginal prolapse surgery, transurethral bladder catheterization is used to control urinary output, reduce the possibility of bladder injury, and prevent post-operative urinary retention.

Traditionally, two types of urinary catheters are used. Transurethral catheters, that would remain in place for at least 24 hours to avoid acute post-operative urinary retention (AUR), and suprapubic catheters, placed through the abdomen to reduce the risk of urinary tract infection (UTI).

The duration of the catheter stay in the bladder has been reduced over the years. Generally, it is based on personalized knowledge rather than evidence-based knowledge. All this leads to the fact that the catheter durations in the bladder vary considerably.<sup>3</sup> It

**Address for Correspondence:** Edgardo Castillo Pino, Pelvic Floor Unit, Department of Obstetrics and Gynecology, University of the Republic School of Medicine, Clinical Hospital, Montevideo, Uruguay

**E-mail:** castillopino@gmail.com **ORCID:** orcid.org/0000-0003-0241-9625

**Received:** 08 April 2021 **Accepted:** 16 April 2021

is common to use routine bladder catheterization for up to three days after vaginal hysterectomy.

Prolonged catheterization increases the possibility of UTI, avoids early ambulation, prolongs hospital stay, and also has negative effects on postoperative well-being.<sup>3-7</sup> In contrast, short-term catheterization reduces hospital stay, costs, and allows early mobilization after the operation.<sup>8-10</sup> The duration of bladder drainage to avoid urinary retention after gynecological surgery varies considerably.<sup>11</sup> Early catheter removal can lead to AUR due to reflex pain at the operation site and overfilling of the bladder after prolapse surgery could have a negative effect on the surgical outcome.<sup>6</sup> The duration of the catheter stay after the operation is based on custom rather than evidence. A Cochrane review of catheter policies after urogenital surgery was unable to make any consistent recommendations.<sup>12</sup> Therefore, the objective of the present study was to evaluate the effectiveness and compare the postoperative complications of early, intermediate or late removal of the urinary catheter after vaginal cystocele repair surgery (with or without vaginal hysterectomy) and to determine the prevalence of asymptomatic UTI and AUR.

## MATERIALS AND METHODS

A prospective, randomized study was designed. Women assisted by the medical team of the Pelvic Floor Unit were selected during the period from March 1<sup>st</sup>, 2019 to March 1<sup>st</sup>, 2020. The study was approved by the Ethics Committee from the University of the Republic School of Medicine, Clinical Hospital from Montevideo, Uruguay (no: 81, date: November 29<sup>th</sup>, 2017). All included patients signed a consent, after being informed about the study. The inclusion criteria were uterine or vaginal prolapse with asymptomatic primary cystocele  $\geq$  stage II according to POP-Q with indication for site-specific vaginal repair surgery such as isolated anterior colporrhaphy or associated with vaginal hysterectomy or with Fothergill-Manchester and Richter procedures. Asymptomatic cystocele is the term referred to if there was no urinary incontinence.

Women with stage I prolapse, stress urinary incontinence, history of previous urinary retention, preoperative urinary tract infection, renal function compromise parameters (blood urea  $>40$  mg/dl, serum creatinine  $> 1$  mg/dl), diabetics, those withintra-operative bladder injury and patients who did not give their consent, were excluded from the study.

The included patients were admitted to the hospital where a medical history and detailed physical examination were documented. Data on age, menopausal status, stage of prolapse (POP-Q) and type of intervention performed were recorded.

At the time of the intervention, a urinary catheter (Foley 16) was inserted in all patients. 71% of the patients underwent spinal anesthesia. After the intervention, a liquid diet was started followed by a normal diet. All patients received intravenous antibiotics for 3 days.

This randomized clinical trial included three groups of patients who underwent vaginal repair surgery with native tissues. All the patients were operated on by the same surgical team.

Randomization was performed with sequentially numbered, sealed envelopes prepared by an independent investigator.

After surgery, the urinary catheter was removed according to randomization in three groups, 24, 48, and 72 hours postoperatively, that is, groups 1, 2, and 3, respectively. After catheter removal, if the patient failed to spontaneously void, a re-catheterization was performed.

On the third day after the operation, a microscopic examination of urine and urine culture was systematically performed. Postoperative bacteriuria was defined as a positive urine culture of  $>100,000$  CFU/ml.

Length of stay was defined as the time interval between surgery and discharge from hospital.

The variables analyzed were the re-catheterization rate to assess the risk of AUR during hospitalization, the risk of asymptomatic UTI by performing urine culture and the duration of hospital stay.

From the statistical analysis, the calculation of the percentage frequencies was considered, and the chi-square test ( $\chi^2$ ) was used to search for association.

## RESULTS

In total, 73 women were recruited for this study. They were assigned to three groups with the following distribution, 27 in group 1, 23 in group 2 and 23 in group 3.

All patients had similar indications for vaginal surgery. The age and menopausal status are shown in Table 1.

There were no major intraoperative complications requiring a patient to be removed from the study protocol. Patients were divided into four age groups: less than 51 years, 51 to 60 years, 61 to 70 years and over 71 years old. The mean age was 66.55 (standard deviation  $\pm 10.97$ ). Forty-seven patients (64.4%) underwent vaginal hysterectomy with pelvic floor repair, 22 surgeries (30.1%) with anterior colporrhaphy, two surgeries for repair of apical prolapse by Richter's operation (2.7%) and two Manchester-Fothergill operations (2.7%).

Most vaginal hysterectomies with pelvic floor repair were performed in the group of women 60 to 69 years of age. 95.9% of cases are postmenopausal women.



Preoperatively, the degree of prolapse according to the POP-Q quantification system was 20.5% with POP-Q II, 60.3% with POP-Q III and 19.2% with POP-Q IV.

Postoperatively, UTI was observed in 7.4%, 17.4%, and 13% in groups 1, 2, and 3, respectively (Figure 1). No statistically significant association was found between the presence of UTI and bladder catheterization time ( $\chi^2=1.3$ ,  $p=0.512$ ). It was observed that 4.1% of total patients presented with AUR, the majority was from group 2 (Table 2)

Of twenty-seven patients in group 1, 3.7% had AUR and required re-catheterization (Figure 2). Of group 2, 8.3% required re-catheterization due to retention. No retention was observed in any of the patients in group 3 (Table 1).

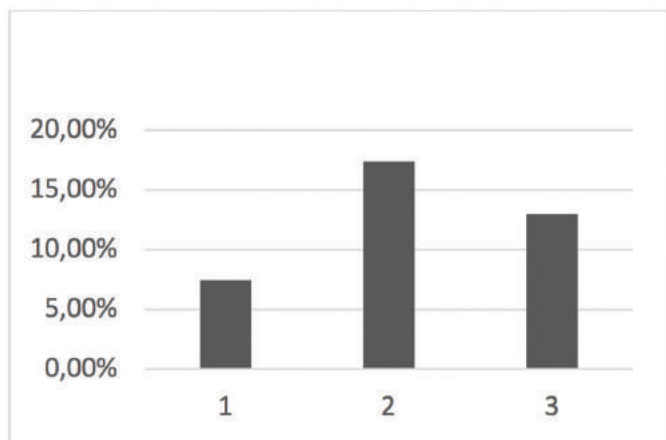

Figure 1 . UTI by assigned groups  
UTI: Urinary tract infection

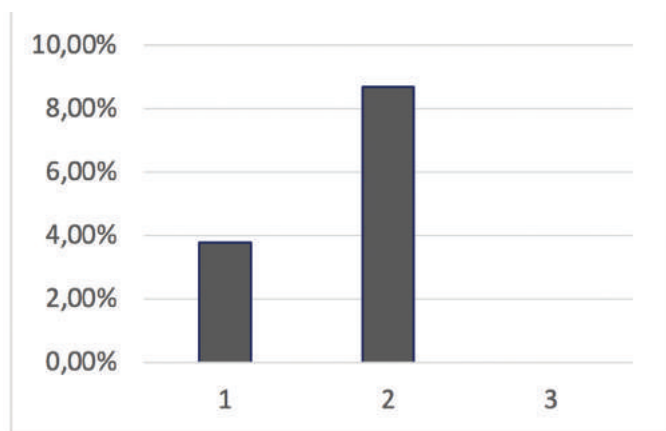

Figure 2. AUR by assigned groups  
AUR: Acute urinary retention

There were no differences between the groups as the difference between UTI was not statistically significant. The hospital stay was three days for most patients, except for one patient in group 2 who had a five-day stay due to urinary retention.

Positive bacterial culture was found in 7.4% of patients in group 1, 17.4% in group 2, and 13% in group 3 (Table 2). The most common bacteria was *E. coli* (67%), followed by *Klebsiella pneumoniae* (22%) and *Proteus mirabilis* (11%).

**Table 1. Participant characteristics**

Groups	1 (24 Hs) (n=27)	2 (48 Hs) (n=23)	3 (72 Hs) (n=23)	Total (n=73)
Premenopausal	11.10%	0	0	4.10%
Postmenopausal	88.90%	100%	100%	95.90%
Age ≤50	11.10%	0	0	4.10%
Age 51–60	14.80%	21.70%	13.00%	16.40%
Age 61–70	51.80%	26%	47.80%	42.50%
Age ≥71	22.20%	52%	39.10%	37%
POP Q II	23%	16.70%	21.70%	20.50%
POP Q III	61.50%	66.70%	52.20%	60.30%
POP Q IV	15.50%	16.70%	26.10%	19.20%
Regional anesthesia	26%	23%	22%	21%
General anesthesia	11%	8%	10%	9%

Values are given as number (percentage) unless otherwise indicated  
POP-Q: Pelvic Organ Prolapse Quantifications System; Hs: Hours; n: Number

**Table 2. A comparison of the rates of UTI, AUR and hospital stay in the different groups**

Groups	1 (24 Hs) (n=27)	2 (48 Hs) (n=23)	3 (72 Hs) (n=23)	Total (n=73)
UTI	7.4%	17.4%	13.00%	12.3%*
AUR	3.8%	8.3%	0%	4.1%
Hospital stay 3 days	100%	95.8%	100%	98.6%

p=0.512

\*: The percentage frequencies and the value of p were calculated  
UTI: Urinary tract infection; AUR: Acute urinary retention; Hs: Hour; n: Number

## DISCUSSION

Maintaining a urinary catheter in the bladder for an extended period of time during the postoperative period has changed over the years. Evidence and experience have shown that prolonging the duration of a urinary catheter had no additional benefit.

The urinary catheter is commonly used to assess urinary output and to prevent postoperative urinary retention. Bladder catheterization is not a harmless procedure. Hospital-acquired UTI is associated with the use of urinary catheters. UTI increases hospital stay, is expensive to treat, and causes discomfort to patients.

A previous study compared catheter removal after one day and three days;<sup>13</sup> the authors of that study discussed perioperative considerations to prevent acute urine retention. Another study reported a group of patients who had their urinary catheters removed immediately after surgery.<sup>10</sup> The authors recommended removing urinary catheter after three hours with careful monitoring of the patient's voiding.

The immediate removal of the catheter may cause difficulty in early ambulation and the recovery of bladder function due to the residual effect of regional anesthesia after using intra-spinal opioids.

In our study, these aspects were considered, and it was decided to remove the catheter 24 hours after the operation.

There are studies that show that the retention rate was higher in the prolonged catheterization group.<sup>14,15</sup> However, other studies showed that retention rates were more common in the early removal group compared to the late removal group.<sup>6,10,13,14,16-19</sup> Hakvoort et al.<sup>6</sup> reported that in women with anterior colporrhaphy, if the catheter was removed within 24 hours, 40% required a new catheterization. Similarly, Alessandri et al.<sup>8</sup>, in a randomized clinical study in patients undergoing vaginal hysterectomy, found a relatively high rate of re-catheterization (18.8%) in the immediate removal group.

In our study, re-catheterization due to urine retention was found in 4.1%, being higher in group 2 (8.7%).

Most studies report a higher incidence of UTI when the urinary catheter remains for longer.<sup>6,10,16</sup> A reduction in UTIs is important since they represent 40% of all hospital-acquired infections and 80% of these are associated with the use of urinary catheters.<sup>19</sup> Our study found a high incidence of UTI in all groups (7.4%, 17.4% and 13%), but there were no statistically significant differences.

In 2004, a randomized clinical trial determined the benefits of prolonged urinary catheterization after prolapse surgery.<sup>6</sup> One hundred patients were assigned into two groups. One group (n=50) where the catheter was removed on the fifth day after the operation and the other (n=50) where the removal was on the day after the operation. Positive urine cultures were found in 40% of cases in the prolonged catheterization group compared to 4% in the non-prolonged group (odds ratio: 15, 95% confidence interval: 3.2–68.6). The authors concluded that removal of the urinary catheter is preferable in the morning after surgery and prolonged catheterization should only be performed when there are specific indications.

A systematic Cochrane review in 2006 of urinary catheter management after urogenital surgery in adults showed a lower rate of UTI when the catheter was removed early.<sup>12</sup> The authors concluded that the use or not of a particular policy is generally

based on the balance between the risks of morbidity (especially infection) and the risks of repositioning a catheter.<sup>12</sup>

Bacteriuria from a single bladder catheterization was observed in 3% to 4%, while if catheterization was not required, there was a 1% risk of acquiring bacteriuria during hospitalization.<sup>20</sup> Permanent catheters are particularly vulnerable to colonization by bacterial biofilms.<sup>21,22</sup> Receiving prophylactic antibiotics reduces the rate of bacteriuria and other signs of infection in surgical patients who undergo bladder drainage for at least 24 hours after surgery.<sup>19</sup> In 2010, a study compared intermittent and suprapubic catheterization after anterior or posterior colporrhaphy.<sup>21</sup> The length of hospital stay and total length of catheterization were significantly shorter for the intermittent group.<sup>21</sup> In 2011, a randomized clinical trial assessed the management of abnormal residual volume after prolapse surgery, comparing the use of intermittent and transurethral catheterization. A twenty-fold reduction in the risk of urinary infection with intermittent catheterization was demonstrated.<sup>23</sup> Furthermore, it was found that patients preferred intermittent catheterization.<sup>23</sup>

In 2017, a randomized controlled trial,<sup>24</sup> compared immediate removal of the urinary catheter versus a suprapubic catheter after vaginal prolapse surgery. It was observed that a permanent catheter is not necessary in the postoperative period for many women.

Reduction in length of stay and early mobilization are consequent to avoiding a permanent catheter.<sup>25,8</sup>

The present randomized controlled trial was performed to compare immediate 24-hour removal versus use of a permanent catheter with removal at 48 and 72 hours.

The strengths of the study are being a prospective randomized study with defined inclusion and exclusion criteria, and that all the patients were operated on by the same surgical team. In addition, a study protocol with a similar length of hospital stay was followed in each group to reduce the chances of bias. The limitations were that various types of surgery were included, the sample size and the use of general anesthesia in some cases. Another limitation of the study was that groups 2 and 3 did not include premenopausal patients.

Our research has shown that it is not necessary to use a permanent urinary catheter for longer than 24 hours after vaginal surgery for pelvic organ prolapse. A short duration of catheterization with removal at 24 hours is safe and does not cause an increase in retention or urinary infection. Prolonged catheterization does not offer benefits to patients and unnecessarily lengthens hospital stay.

## CONCLUSION

Removal of the urinary catheter after 24 hours following vaginal hysterectomy with anterior colporrhaphy decreased hospital stay and UTI rates.

## Contributions

Surgical and Medical Practices: E.C.P., N.B., Va.A., V.A., Concept: E.C.P., Design: E.C.P., N.B., Data Collection or Processing: E.C.P., N.B., Va.A., V.A., Analysis or Interpretation: E.C.P., N.B., Literature Search: V.A., Writing: E.C.P.

## Ethics

**Ethics Committee Approval:** Ethics Committee from the University of the Republic School of Medicine, Clinical Hospital from Montevideo, Uruguay (no: 81, date: November 29<sup>th</sup>, 2017)

**Informed Consent:** All included patients signed a consent, after being informed about the study.

**Peer-review:** Externally peer-reviewed.

## DISCLOSURES

**Conflict of Interest:** No conflict of interest was declared by the authors.

**Financial Disclosure:** The authors declared that this study received no financial support

## REFERENCES

- Hodges KR, Davis BR, Swaim LS. Prevention and management of hysterectomy complications. *Clin Obstet Gynecol* 2014; 57: 43-57.
- Clarke-Pearson DL, Geller EJ. Complications of hysterectomy. *Obstet Gynecol* 2013; 121: 654-73.
- Vierhout ME. Prolonged catheterization after vaginal prolapse surgery. *Acta Obstet Gynecol Scand* 1998; 77: 997-9.
- Dunn TS, Shlay J, Forshner D. Are in-dwelling catheters necessary for 24 hours after hysterectomy? *Am J Obstet Gynecol* 2003; 189: 435-7.
- Andersen JT, Heisterberg L, Hebjørn, et al. Suprapubic versus transurethral bladder drainage after colposuspension/vaginal repair. *Acta Obstet Gynecol Scand* 1985; 64: 139-43.
- Hakvoort RA, Elberink R, Vollebregt A, Ploeg T, Emanuel MH. How long should urinary bladder catheterisation be continued after vaginal prolapse surgery? A randomised controlled trial comparing short term versus long term catheterisation after vaginal prolapse surgery. *BJOG* 2004;111:828-30.
- Schiøtz HA, Tanbo TG. Postoperative voiding, bacteriuria and urinary tract infection with Foley catheterization after gynecological surgery. *Acta Obstet Gynecol Scand* 2006; 85: 476-81.
- Alessandri F, Mistrangelo E, Lijoi D, Ferrero S, Ragni N. A prospective, randomized trial comparing immediate versus delayed catheter removal following hysterectomy. *Acta Obstet Gynecol Scand* 2006; 85: 716-20.
- Dunn TS, Shlay J, Forshner D. Are in-dwelling catheters necessary for 24 hours after hysterectomy? *Am J Obstet Gynecol* 2003; 189: 435-7.
- Glavind K, Mørup L, Madsen H, Glavind J. A prospective, randomised, controlled trial comparing 3 hour and 24 hour postoperative removal of bladder catheter and vaginal pack following vaginal prolapse surgery. *Acta Obstet Gynecol Scand* 2007; 86: 1122-5.
- Schiøtz HA, Tanbo TG. Postoperative voiding, bacteriuria and urinary tract infection with Foley catheterization after gynecological surgery. *Acta Obstet Gynecol Scand* 2006; 85: 476-81.
- Phipps S, Lim YN, McClinton S, Barry C, Rane A, N'Dow J. Short term urinary catheter policies following urogenital surgery in adults. *Cochrane Database Syst Rev* 2006; 2: CD004374.
- Baldini G, Bagry H, Aprikian A, Carli F. Postoperative urinary retention: anesthetic and perioperative considerations. *Anesthesiology* 2009; 110: 1139-57.
- Summitt RL Jr, Stovall TG, Bran DF. Prospective comparison of indwelling bladder catheter drainage versus no catheter after vaginal hysterectomy. *Am J Obstet Gynecol* 1994; 170: 1815-8.
- Sekhavat L, Farajkhoda T, Davar R. The effect of early removal of indwelling urinary catheter on postoperative urinary complications in anterior colporrhaphy surgery. *Aust N Z J Obstet Gynaecol* 2008; 48: 348-52.
- Kamilya G, Seal SL, Mukherji J, Bhattacharyya SK, Hazra A. A randomized controlled trial comparing short versus long-term catheterization after uncomplicated vaginal prolapse surgery. *J Obstet Gynaecol Res* 2010; 36: 154-8.
- Dunn TS, Shlay J, Forshner D. Are in-dwelling catheters necessary for 24 hours after hysterectomy? *Am J Obstet Gynecol* 2003; 189: 435-7.
- Liang CC, Lee CL, Chang TC, Chang YL, Wang CJ, Soong YK. Postoperative urinary outcomes in catheterized and non-catheterized patients undergoing laparoscopic-assisted vaginal hysterectomy--a randomized controlled trial. *Int Urogynecol J Pelvic Floor Dysfunct* 2009; 20: 295-300.
- Lusardi G, Lipp A, Shaw C. Antibiotic prophylaxis for short-term catheter bladder drainage in adults. *Cochrane Database Syst Rev* 2013; 2013: CD005428.
- Nicolle LE. Catheter-related urinary tract infection. *Drugs Aging* 2005; 22: 627-39.
- Stickler DJ. Bacterial biofilms in patients with indwelling urinary catheters. *Nat Clin Pract Urol* 2008; 5: 598-608.
- Schiøtz HA. Comparison of 1 and 3 days' transurethral Foley catheterization after vaginal plastic surgery. *Int Urogynecol J* 1995; 6: 158-61.
- Hakvoort RA, Thijs SD, Bouwmeester FW, et al. Comparing clean intermittent catheterisation and transurethral indwelling catheterisation for incomplete voiding after vaginal prolapse

- surgery: a multicentre randomised trial. BJOG 2011; 118: 1055-60.
24. Bray R, Cartwright R, Digesu A, Fernando R, Khullar V. A randomised controlled trial comparing immediate versus delayed catheter removal following vaginal prolapse surgery. Eur J Obstet Gynecol Reprod Biol 2017; 210: 314-8.
25. Dixon L, Dolan LM, Brown K, Hilton P. RCT of urethral versus suprapubic catheterization. Br J Nurs 2010; 19: 7-13.



# Chronic pelvic pain associated with Nutcracker Phenomenon and pelvic congestion: a case report

ILEANA SÄNGER<sup>1</sup>, OSCAR ROMERO GURAL<sup>2</sup>, CARLOS SARSOTTI<sup>1</sup>, MARTINA SANTILLÁN ITURRES<sup>3</sup>

<sup>1</sup>Grupo de Diagnóstico y Rehabilitación de las Disfunciones del Piso Pelvico (GEDREP), Buenos Aires, Argentina

<sup>2</sup>Phlebology Section, Fundacion Favaloro, Buenos Aires, Argentina

<sup>3</sup>Responsible of English Translation, Medicine Faculty, Buenos Aires University, Argentina

## ABSTRACT

The objective of this article is to present the case of a nulliparous female patient with a history of chronic pelvic pain associated with the nutcracker phenomenon (NCP), which was evaluated in our centre, with diagnosis and treatment using endovascular techniques and postoperative results. The case report of an 18-year-old female patient with a status of severe emotional and social deterioration resulting from four years of crippling pelvic pain along with numerous and unsuccessful surgical and medical support treatments is presented. In a review of the symptoms and complementary studies, the presence of pelvic congestion secondary to a NCP was identified as the origin of its clinic, an unusual pathology in nulliparous patients and with no consensus regarding on its optimal treatment. An embolization of the left gonadal vein (LGV) and left gluteal vein with sandwich technique was performed and the self-expanding vein stent was implanted in the left renal vein (LRV).

The patient recovered satisfactorily with immediate relief of pain.

Pelvic congestion syndrome should be considered in the differential diagnosis of chronic pelvic pain, even in nulliparous women. There are a wide range of treatment possibilities for this syndrome, depending on what causes it, clinical status and the anatomic characteristics of each patient. Although there is no standardized endovascular technique, in this case the embolization of the LGV and the left lower gluteal vein as well as the placement of a stent on the LRV, were proved to be safe and effective, with complete remission of pain. Additional studies would be useful to investigate the best treatment in cases of pelvic congestion and NCP.

**Keywords:** Pelvic pain; venous congestion; pelvic congestion syndrome; renal nutcracker phenomenon; renal nutcracker syndrome; renal vein; May-Thurner syndrome

## INTRODUCTION

Chronic pelvic pain is a debilitating disease with considerable impact on quality of life and productivity. It is defined as non-menstrual or non-cyclic pelvic pain, with duration of at least 6 months, sufficiently intense to interfere in daily activities and

requiring clinical or surgical treatment. One of the main causes of chronic pelvic pain is pelvic congestion syndrome (PCS), characterized by varying degrees of pain, dysuria, dysmenorhea, dyspareunia, and vulvar congestion, often associated with vulvar varicose veins.<sup>1</sup> A study by Asciutto et al.<sup>2</sup> showed that the left

This article has been published as in ePub format previously with DOI number 10.34057/PPj.2020.39.04.AOP.A

**Address for Correspondence:** Ileana Sänger, Grupo de Diagnóstico y Rehabilitación de las Disfunciones del Piso Pelvico (GEDREP), Buenos Aires, Argentina

**E-mail:** ilesaenger@me.com **ORCID:** orcid.org/0000-0003-0714-5010

**Received:** 28 July 2020 **Accepted:** 21 October 2020

gonadal vein (LGV) and right internal iliac vein are the most frequently involved in PCS (57.7% each).

Laboratory tests often reveal signs of microhematuria, which is possibly associated with nutcracker syndrome (NCS), an anatomic variant in which the superior mesenteric artery (SMA) and the aorta obstructed the left renal vein (LRV), causing reflux from this vein and the LGV. According to Robertson & McCuaig NCS is a rare disease.<sup>3</sup> Although the exact prevalence of NCS as a cause of PCS has not been quantified, the condition should always be suspected, in view of its importance in the presentation of PCS.

This article describes a case of PCS secondary to a Nutcracker phenomenon (NCP), diagnosed and treated with endovascular techniques in a private clinic at Ciudad Autónoma de Buenos Aires, Argentina.

The patient agreed to the publication of this case report and signed an informed consent form.

## CASE REPORT

An 18-year-old female patient with a four years history of hypogastric and lumbar pain, was seen in our clinic. Her main complaint was visceral hypogastric pain, with no irradiation to any site other than the hypogastric area. It worsens with the standing position and movement, for this reason she was barely able to walk. Periods make this pain even worse and she referred that the only thing that alleviates her pain was the resting position. Quality of life assessment showed a young lady with a Karnofsky Index (KI)<sup>4-5</sup> performance status of 3/4 and a visual analogue scale (VAS) 10/10 in terms of pain. Physical examination was normal other than lower limb telangiectasias. She was free from lower limb oedema and other comorbidities. During all these years, she saw many specialists varying from gynaecology, rheumatology, gastroenterology, psychology and psychiatry. Transvaginal ultrasound could not be done because she was not sexually active. Abdominal ultrasounds that included Doppler scans and pelvic magnetic resonance imagings (MRIs) were considered normal.

She received many treatments including surgical procedures. She was treated by conservative treatment with phlebotonics, dienogest 2 mg/day and many different analgesics. Two laparoscopies, by two different specialists, in order to rule out endometriosis were done, being both negative.

Next, a phlebogram was indicated. It revealed a significant reduction of the LRV in the mid third, in the topography of the passage between the SMA and the aorta, providing evidence of Nutcracker phenomenon (Figure 1a and 1b). Also, a left common iliac vein compression by the right common iliac artery

suggesting May-Thurner phenomenon (Figure 2) was observed. After these flebographies were done, in two different institutions, with the opinion that nothing was conclusive and could be done, a superior hypogastric plexus block under tomographic control was done. It also did not work. After all this, she was confined at home under psychiatric treatment as she was seriously depressed

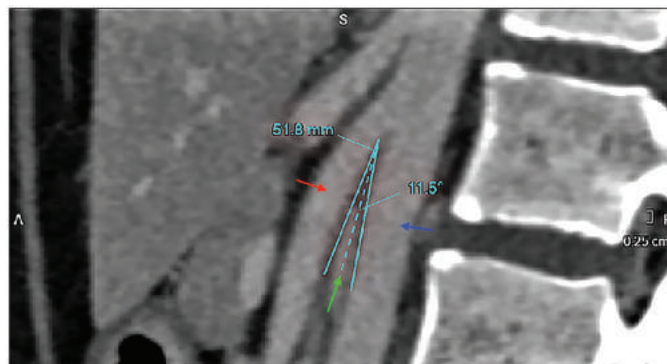

**Figure 1a.** Sagittal view phlebogram, blue arrow aorta artery, red arrow superior mesenteric artery, in the middle with a green arrow left renal vein

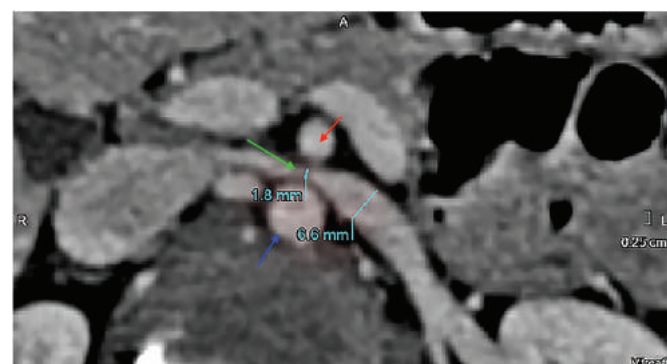

**Figure 1b.** Phlebogram. Axial section. Green arrow shows LRV Stenosis, red arrow SMA, blue arrow aorta artery  
LRV: Left renal vein, SMA: Superior Mesenteric Artery

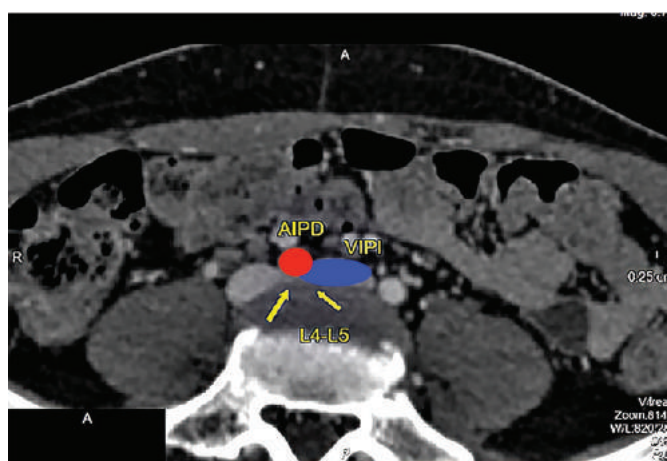

**Figure 2.** May-Thurner phenomenon, left common iliac vein (VIPI) compression (blue) by the right common iliac artery (AIPD) (red)  
AIPD: Arteria iliaca primitiva derecha (in Spanish); VIPI: Vena ilíaca primitiva izquierda (in Spanish)

without resolution of pain.

On this first visit to our office, with us the exactly 80<sup>th</sup> physician consulted, her parents let us know that besides looking for our opinion, and because of a thorough google search, they have already scheduled a new consultation with another vascular surgical service. After seeing all the studies brought by the patient and examining her, we agreed with this, as for us the pain was probably related to a vascular condition because of its clinical characteristics and the NCP seen at the phlebogram already done. Due to her condition of practically feeble, as she was defined by her psychiatrist. So, we seriously considered re-examining the vascular anatomy with a new plebography, looking for a possible surgical procedure and not to go for further medical treatment.

The last flebography clearly showed LGV insufficiency (Figures 3a and 3b) and ipsilateral adnexal varicose veins suggesting PCS (Figure 4). Because of this, the decision of endovascular surgical treatment was offered to the patient and her family. At least primarily.

An endovascular resolution was performed by using a double approach (jugular and femoral veins). Local anaesthesia and IV sedation were used. At the femoral level a 7 Fr introducer and Pigtail catheter were placed for the phlebography. A 12 Fr introducer was used through the internal jugular vein. Zip Wire, Amplatz guides and a right coronary catheter were used for LRV cannulation. Pressures of significant cavo-renal gradient (2 mmHg) were ruled out. Phlebography with derivative pathway evaluation protocol at 360°, where sign of previous Nutcracker was seen, showed imprints of LRV, which evidences retrograde flux through ascending lumbar system and LGV. Signs of severe pelvic congestion from gonadal veins and left lower gluteal vein were also seen Figure 3a, 3b and 4. Initially the embolization of left gonadal and lower gluteal veins was performed, with the sandwich technique, using foam (etoxiesclerol 2%)-coils-foam, Controlled Release Coils (Concerto®.Medtronic) 18x40 cm (0.018) (Figure 5). LRV was implanted with a self-expanding nitinol vein 16x60 mm stent (Abre®. Medtronic) Figure 6a and 6b. Control phlebography showed disappearance of the described collateral pathways and signs of pelvic congestion. Anticoagulation protocol was started with Rivaroxaban, 20 mg/day for 6 months and anti-aggregation with Clopidogrel, 75 mg daily for 3 months. There were no complications during the angiographic procedure or the immediate postoperative period. The patient recovered satisfactorily with immediate relief of pain.

At 6 months, the patient referred that she is fully satisfied with the treatment and she scored her pain 0/10 in a VAS, and a

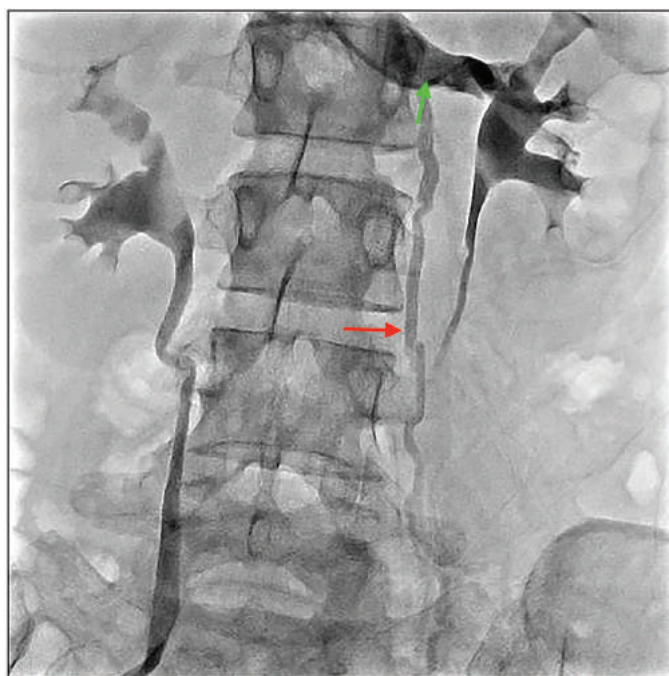

**Figure 3a.** Flebography. Green arrow shows enlarged LRV, red arrow shows left gonadal vein  
LRV: *Left renal vein*

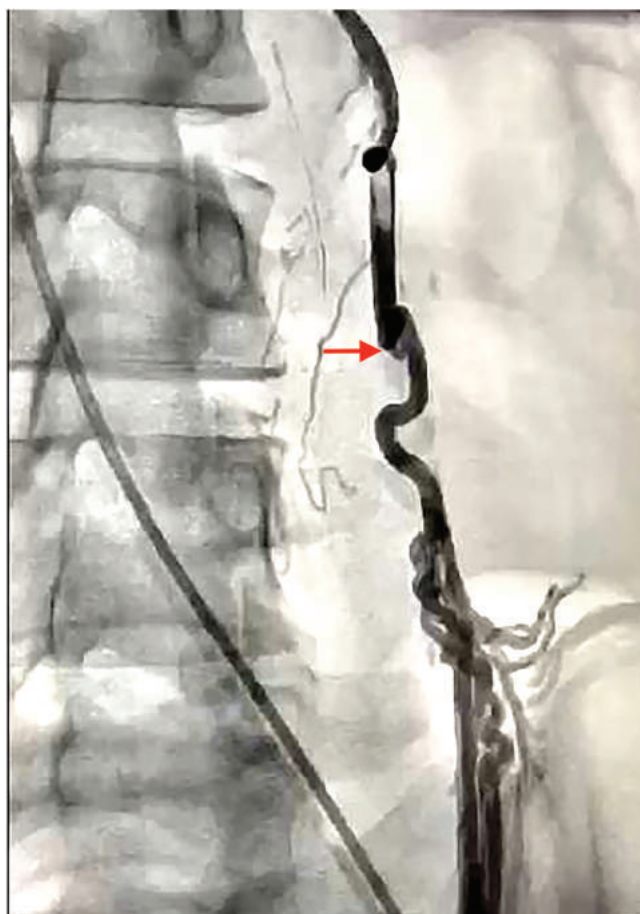

**Figure 3b.** LGV insufficient  
LGV: *Left gonadal vein*

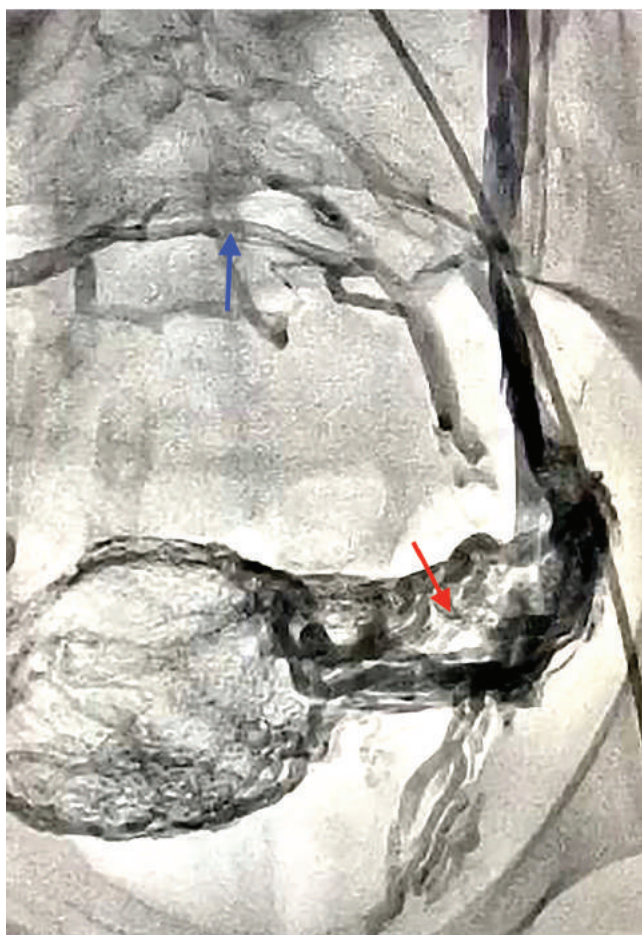
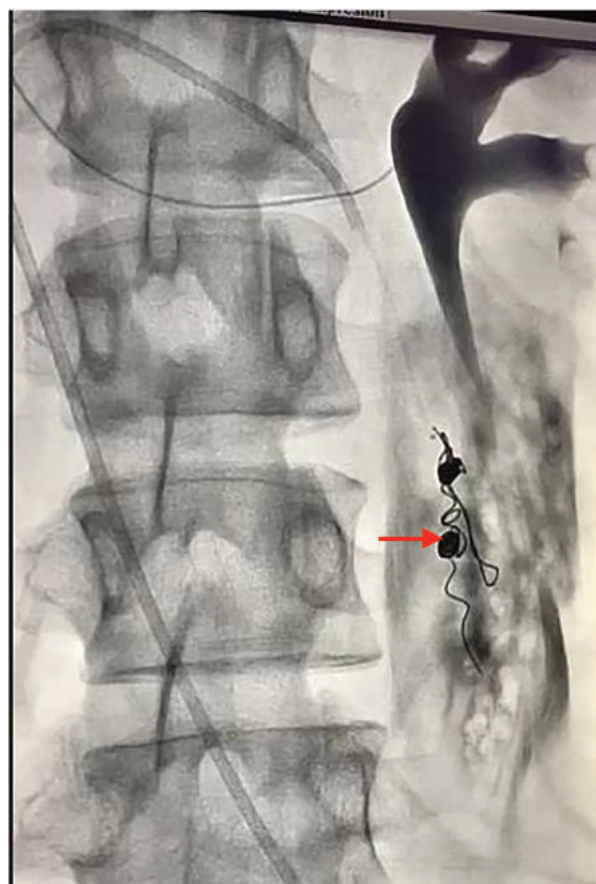

**Figure 4.** Red arrow on adnexal varicose veins, blue arrow on sacral collateral veins

performance status 0/4 according to the KI.

### DISCUSSION

NCS generally affects women aged from 20 to 40 years, especially multiparous women. The venous reflux provokes varicose veins in the deep and superficial venous pelvic plexus and is responsible for a typical clinical status comprising left flank pain and chronic abdominal pain. In men, the syndrome may manifest in a similar way and has been described as one of the causes of varicocele.<sup>6-8</sup> The NCP is due to compression of the LRV, most often between the aorta and the SMA, with debilitation of blood flow that is frequently accompanied by distension of the hilar portion of the vein. The NCS is the clinical equivalent of the NCP, characterized by a complex of symptoms with substantial variations. The more common examples include haematuria and proteinuria, flank pain, pelvic congestion in female patients, and varicocele in male patients.<sup>7-8</sup> The exact prevalence of NCS is unknown, partly because of an absence of definitive diagnostic criteria and the variability of symptomatic presentation. Patients can exhibit the condition at any age from infancy to the seventh



**Figure 5.** Embolization of the LGV, red arrow on the coils  
LGV: Left gonadal vein

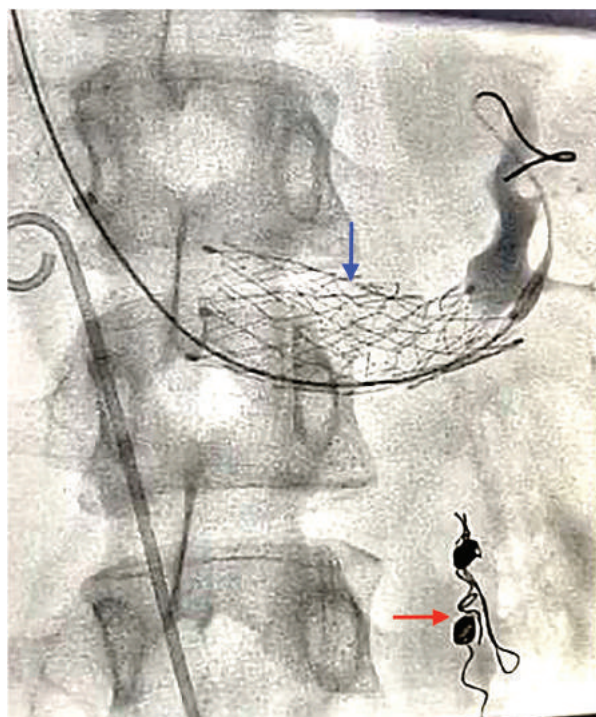

**Figure 6a.** Red arrow shows the coils on the LGV, blue arrow shows the stent on the LRV  
LGV: Left gonadal vein, LRV: Left renal vein





**Figure 6b.** Control phlebography, disappearance of the collateral pathways and signs of pelvic congestion, without contrast material on the LGV  
LGV: Left gonadal vein

decade of life, with peaks in youth (second to fourth decade), because of the rapid increase in height and development of vertebral bodies during puberty which can narrow the angle between the aorta and the SMA at middle-age.<sup>8-11</sup> The prevalence of NCS was reported to be greater among women; however, later studies showed that this condition is equally prevalent among genders.<sup>6</sup> In this particular case, and though she was a really young lady, because of her own description of the problem in the standing position, this made us pay attention to a possible vascular etiology.

Depending on the specific manifestations, NCS may be identified by a number of different medical specialists and, although it is associated with considerable morbidity, diagnosis tends to be difficult and is usually late.<sup>10</sup> It can be confirmed with the results of imaging exams, including Doppler ultrasonography, tomography, MRI, phlebography, and intravascular ultrasonography.

Treatment for NCS varies depending on the patient's clinical severity and is reserved for symptomatic patients only. According to Macedo et al.<sup>12</sup>, treatment for the syndrome remains controversial, both for indication of treatment and for the best modality to be used for each patient as well. Options include conservative treatment, open surgery with section of the fibrous

ligament between the SMA and the aorta, transposition of the LRV, kidney autotransplantation, and even nephrectomy.<sup>8,12,13</sup> These techniques can also be performed via open surgery or laparoscopic access, but experience is limited.<sup>14</sup> Since 1996, endovascular approaches gained popularity, and have even been recommended as first-line treatment.<sup>15</sup> Endovascular stent placement is usually preferable to open surgery, because of the long duration of renal congestion, the greater possibility of complications in these cases, and the need for extensive dissection in this type of operation.<sup>12</sup> Additionally, there is the possibility of simultaneous embolization of the gonadal vein and/or sclerosis with polidocanol directly into the pelvic varicose veins during the procedure. Complications include stent migration, intra-stent restenosis, haemorrhage, and venous occlusion.<sup>10</sup> With regard to LGV embolization, a literature review<sup>12</sup> reports relief from symptoms in 56%–98%. In our patient, as we assumed that the presence of such invalidating symptoms of lower back and pelvic pain, were due the unusual kind of pelvic congestion associated with Nutcracker phenomenon we saw, which was confirmed by colour echodoppler, computed angiography and phlebography we counselled the patient for a more extended procedure, involving all the sites we recognized as abnormal. The embolization was performed with sandwich technique with foam (etoxiesclerol)-controlled coils-foam and the stent implant dedicated to self-expanding vein in the LRV.

We decided to be conservative and wait about the observed in regard to May-Thurner phenomenon. This entity is a common but rarely diagnosed disorder involving left common iliac vein compression by the right iliac artery, with a suspected prevalence of 24% in the general population in retrospective studies of computed tomography scans, and 22% in cadaveric studies.<sup>16-17</sup> Most commonly, the patient will present with symptoms of an underlying deep venous thrombosis, including pain, swelling, and discoloration of the extremity.<sup>16</sup> May-Thurner syndrome is proposed to be the reason why deep venous thrombosis is five times more likely in the left lower extremity versus the right lower extremity.<sup>17</sup> Patients may present as a spectrum of symptoms, from asymptomatic to extensive venous thrombosis in the left lower extremity and/or pulmonary embolism.<sup>18</sup> It seemed that a high degree of clinical suspicion is critical to diagnose NCS as a cause of pelvic chronic pain in a young nulliparous women. There are a wide range of treatment possibilities, depending on clinical status and the anatomic characteristics of each case. In this case, the endovascular technique proved to be safe and effective. The LGV was embolized as well as a stent was placed on the LRV with complete remission of pain.

There is no standard endovascular treatment. While some authors<sup>12</sup> supports indication of routine embolization of the gonadal vein combined with stenting of the LRV, others<sup>19</sup> suggest using only the stent on the LRV and others only the embolization as initial treatment. In view of this, additional studies would be useful to investigate the best treatment in cases of NCS.

Finally, this case taught us that multidisciplinary approach is mandatory to all cases of chronic pelvic pain being simple or very complicated like this.

## ETHICS

**Informed Consent:** The patient agreed to the publication of this case report and signed an informed consent form.

**Peer-review:** Externally peer-reviewed.

## DISCLOSURES

**Conflict of Interest:** There are no conflicts of interest to declare.

**Financial Disclosure:** The authors declared that this study received no financial support.

## REFERENCES

- Nogueira AA, Reis FJC, Poli Neto OB. Abordagem da dor pélvica crônica em mulheres. *Rev Bras Ginecol Obstet* 2006; 28: 733-40.
- Asciutto G, Asciutto KC, Mumme A, Geier B. Pelvic venous incompetence: reflux patterns and treatment results. *Eur J Vasc Endovasc Surg* 2009; 38: 381-6.
- Robertson M, McCuaig R. Pelvic congestion syndrome. *AJUM* 2013; 16: 26-9.
- Karnofsky DA, Burchenal JH. The clinical evaluation of chemotherapeutic agents in cancer. In: MacLeod CM, ed. *Evaluation of chemotherapeutic agents*. 1949; 191-205. New York: Columbia University Press.
- Spitzer WO. State of science 1986: quality of life and functional status as target variables for research. *J Chronic Dis* 1987; 40: 465-71.
- Ferreira M, Lanzotti L, Abuhadba G, Monteiro M, Capotorto L, Spicacci JL. Chronic pelvic pain: the role of the nutcracker syndrome. *J Vasc Bras* 2008; 7: 76-9.
- Correia T, Cardoso A, Soares R, et al. Síndrome de Quebra-nozes: A propósito de um caso clínico. *Acta Urologica* 2007; 24: 49-52.
- Ananthan K, Onida S, Davies AH. Nutcracker Syndrome: An update on current diagnostic criteria and management guidelines. *Eur J Vasc Endovasc Surg* 2017; 53: 886-94.
- He Y, Wu Z, Chen S, et al. Nutcracker syndrome-how well do we know it? *Urology* 2014; 83: 12-7.
- Kurklinsky AK, Rooke TW. Nutcracker Phenomenon and Nutcracker Syndrome. *Mayo Clin Proc* 2010; 85: 552-9.
- Gulleroglu K, Gulleroglu B, Baskin E. Nutcracker syndrome. *World J Nephrol* 2014; 3: 277-81.
- Macedo GL, Santos MA, Sarris AB, Gomes RZ. Diagnóstico e tratamento da síndrome de quebra-nozes (nutcracker): revisão dos últimos 10 anos. *J Vasc Bras* 2018; 17: 220-8.
- Avegerinos ED, McEnaney R, Chaer RA. Surgical and endovascular interventions for nutcracker syndrome. *Semin Vasc Surg* 2013; 26: 170-7.
- Gunka I, Navratil P, Lesko M, Jiska S, Raupach J. Laparoscopic left renal vein transposition for nutcracker syndrome. *Ann Vasc Surg* 2016; 31: 219.e1-5.
- Chen S, Zhang H, Shi H, Tian L, Jin W, Li M. Endovascular stenting for treatment of nutcracker syndrome: report of 61 cases with long-term followup. *J Urol* 2011; 186: 570-5.
- Kibbe MR, Ujiki M, Goodwin AL, Eskandari M, Yao J, Matsumura J. Iliac vein compression in an asymptomatic patient population. *J Vasc Surg* 2004; 39: 937-43.
- May R, Thurner J. The cause of the predominantly sinistral occurrence of thrombosis of the pelvic veins. *Angiology* 1957; 8: 419-27.
- Thijs W, Rabe KF, Rosendaal FR, Middeldorp S. Predominance of left-sided deep vein thrombosis and body weight. *J Thromb Haemost* 2010; 8: 2083-4.
- Costa LA, Silva OF Jr. Tratamento Endovascular da Síndrome do Quebra Nozes: relato de caso. *J Vasc Bras* 2014; 12: 247-51.

Surgical technique adaptable to the individual anatomy  
for the treatment of female stress incontinence with

# SERASIS® JK-Tape®

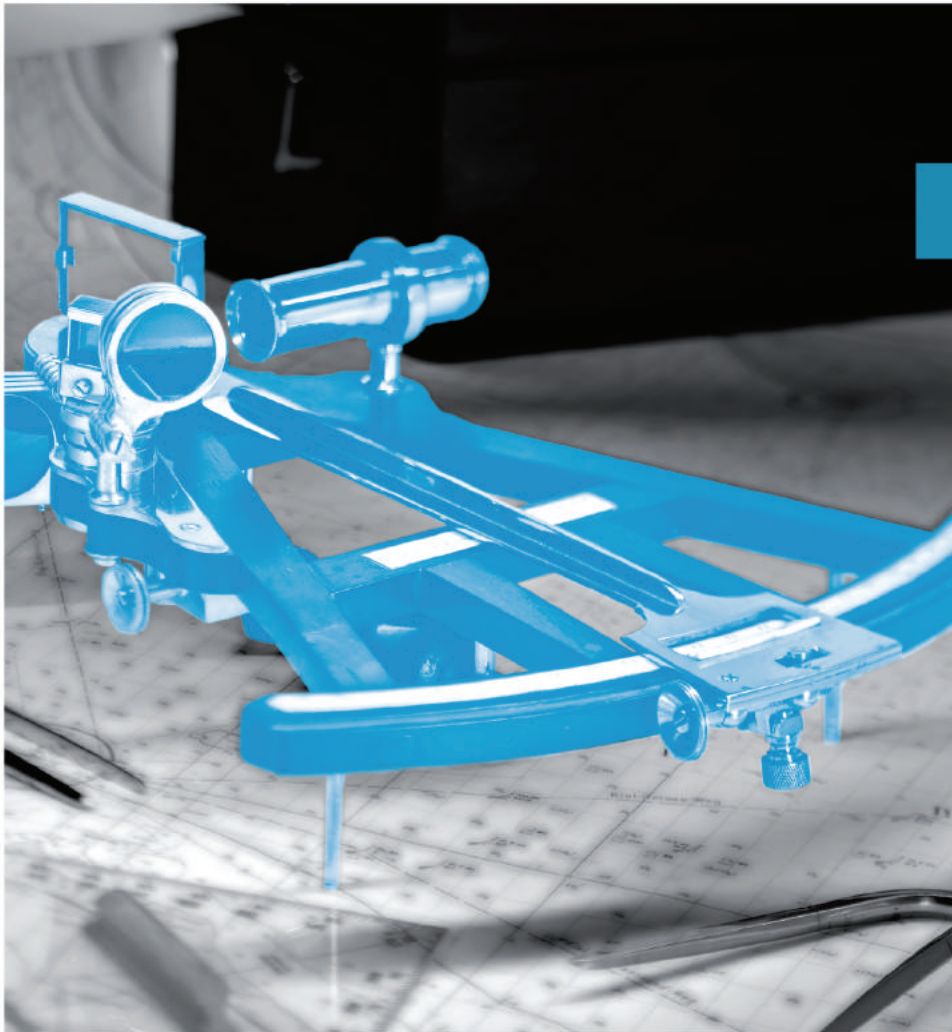

## Advantages

extra slim tape for  
incontinence surgery

suitable for urethras of all  
lengths and mobility

anatomically adapted  
geometry

adjustability

lies reliably flat beneath  
the urethra, thanks to buffer  
zones

reduces the risk of a  
'tethered tape'

keeps its shape under tension

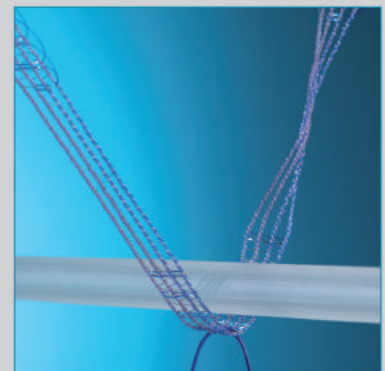
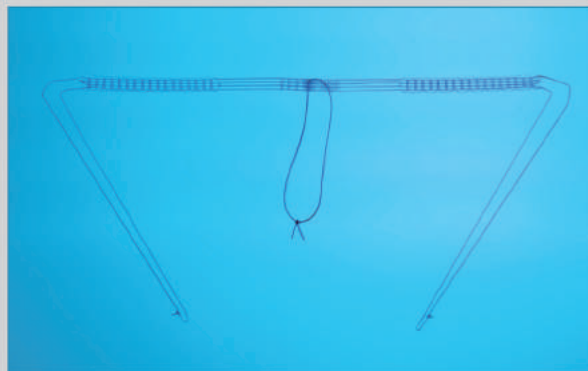
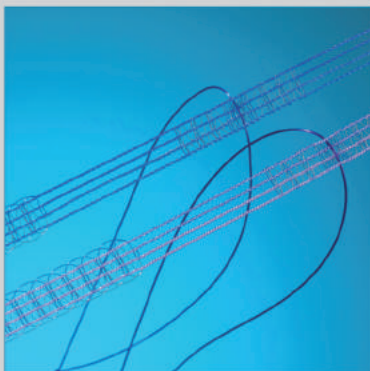

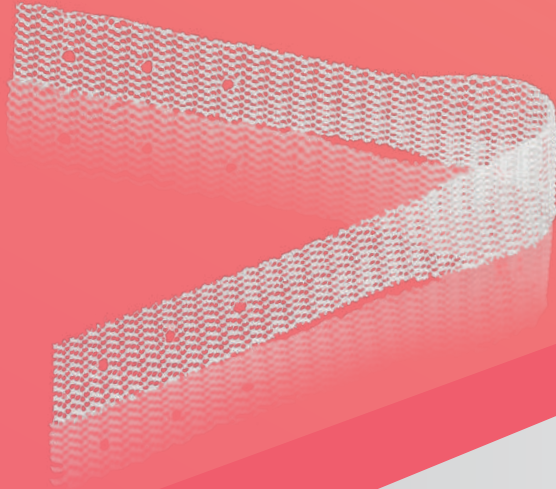

- Splentis provides suspension in a physiologic, central position by bridging the distance between the cervix and the sacrospinous ligaments by bilateral fixation

**Splentis**  
POP TISSUE ANCHORING SYSTEM

- ▶ mesh reinforcement
- ▶ Uterine prolapse
- ▶ Descent of the uterine cervix after subtotal hysterectomy

## Transvaginal Treatment of apical Prolaps

**Promedon**

Urology and Pelvic Floor

- ▶ meshless
- ▶ Uterine prolapse
- ▶ Vaginal vault prolapse

**ANCORIS**  
POP REPAIR SYSTEM

- Apical support for durable results in anterior and posterior repair
- Ancoris to treat women with apical prolapse using a meshless, safe, reliable and minimally invasive procedure

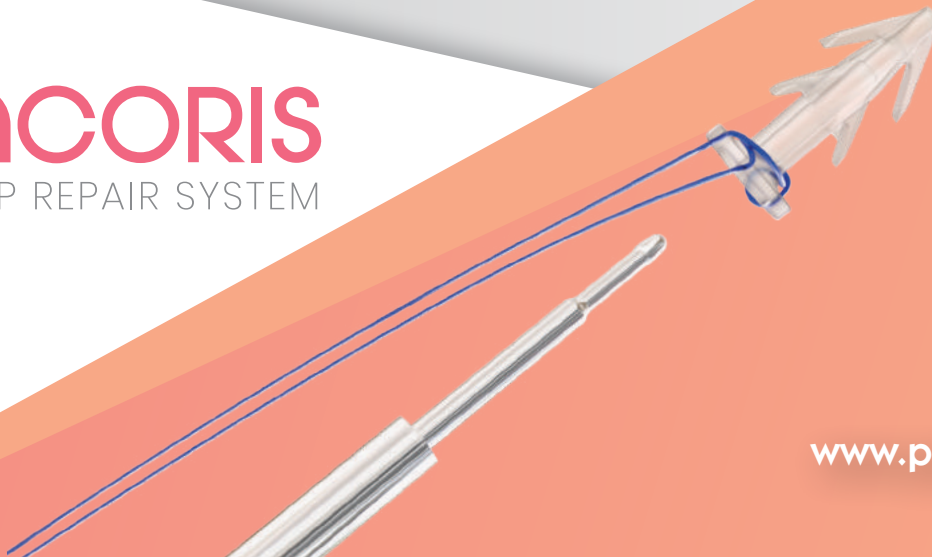

[www.promedon-urologypf.com](http://www.promedon-urologypf.com)